



TECHNICAL DATA

INDUSTRIAL MEDIUM-MU POWER TRIODE 3CX4500F3/YU-108

The Eimac 3CX4500F3/YU-108 is a medium-Mu, ceramic/metal power triode designed primarily for use in industrial radio-frequency heating services. Its air-cooled external plate is rated for 6000 watts of dissipation. Plentiful reserve emission is available from the 525 watt filament, and the grid is rated at 300 watts making this product an excellent choice for severe applications. The 3CX4500F3/YU-108 has flexible leads for the filament connections, and the grid terminates in a rugged flange which may be used for mounting the tube.

GENERAL CHARACTERISTICS¹

ELECTRICAL

Filament: Thoriated Tungsten	
Voltage.....	7.0 ± 0.35 V
Current @ 7.0 volts.....	75 A
Direct Interelectrode Capacitances (grounded cathode) ²	
Cin.....	37.5 pF
Cout.....	0.9 pF
Cgp.....	26 pF
Amplification Factor (average)	22
Frequency of Maximum Rating (CW).....	75 MHz

MECHANICAL

Overall Dimensions:	
Length	18.55 in; 471 mm
Diameter	6.125in; 156 mm
Weight (approx.)	9.5 lb; 4.3 kg
Operating Position.....	Vertical, base up or down
Maximum Operating Temperatures:	
Ceramic/Metal Seals & Envelope.....	250°C
Filament leads at Tube Base	150°C
Cooling	Forced Air
Base.....	Special with flying leads

¹ Characteristics and operating values are based upon performance tests. These figures may change without notice as the result of additional data or product refinement. CPI Eimac Division should be consulted before using this information for final equipment design.

² Capacitance values are for a cold tube as measured in a special shielded fixture in accordance with Electronic Industries Association Standard RS-191.





**RADIO FREQUENCY OSCILLATOR
Filtered DC Power Supply**

**TYPICAL OPERATION UNDER LOADED
CONDITIONS, below 30 MHz:**

Class C

ABSOLUTE MAXIMUM RATINGS:

Plate Voltage.....	9.0	Kilovolts
Plate Current.....	3.0	Ampere
Grid Voltage.....	-1.0	Kilovolts
Grid Current No Load.....	1.0	Ampere
Grid Current Max. Load.....	0.8	Ampere
Plate Input Power.....	25	Kilowatts
Plate Dissipation.....	6	Kilowatts
Grid Dissipation.....	300	Watts

Plate Voltage.....	8.0	kVdc
Plate Current.....	2.75	Adc
Grid Voltage.....	-705	Vdc
Grid Current*.....	0.68	Adc
Peak Grid Voltage*.....	346	V
Grid Resistance.....	1040	Ohms
Driving Power*.....	710	W
Plate Input Power.....	22	kW
Plate Dissipation*.....	4.8	kW
Plate Output Power*.....	15	kW
Resonant Plate Load Impedance*.....	1437	Ohms

*Approximate Values

NOTE: TYPICAL OPERATION data are obtained from direct measurement or by calculation from published characteristic curves. Adjustment of the rf grid voltage (feedback) to obtain the specified plate current at the specified bias and plate voltages is assumed. If this procedure is followed, there will be little variation in output power when the tube is changed.

RANGE VALUES FOR EQUIPMENT DESIGN

	<u>Min.</u>	<u>Max.</u>	
Filament Current @ 7.0 Volts.....	65	78	A
Interelectrode Capacitances ¹ (grounded cathode)			
Cin	31.0	44	pF
Cout		2.0	pF
Cgp.....	23.0	29.0	pF

¹ Capacitance values are for a cold tube as measured in a shielded fixture in accordance with Electronic Industries Association Standard RS-191.

APPLICATION

MOUNTING & SOCKETING – The tube must be operated with its axis vertical. The base of the tube may be up or down at the option of the equipment designer. This product contains a thoriated-tungsten filament and should be protected from shock and vibration.

STORAGE – If a tube is to be stored as a spare it should be kept in its original shipping carton with the original packing material to minimize

the possibility of handling damage. Before storage a new tube should be operated in the equipment for 100 to 200 hours to establish that it has not been damaged and operates properly. If the tube is still in storage 6 months later it should be operated in the equipment for 100 to 200 hours to make sure there has been no degradation. If operation is satisfactory the tube can again be stored with great assurance of being a known-good spare.



COOLING - The maximum temperature rating for the plate core and the ceramic/metal seals of this tube is 250°C and sufficient forced-air cooling must be provided to assure operation at safe tube temperatures. Tube life is usually prolonged if cooling in excess of the absolute minimum requirements is provided.

The filament leads of this tube are attached using soft solder therefore care must be taken to supply sufficient cooling to the base area of the tube to maintain temperatures below 150°C to avoid melting the solder or loosening of the leads.

The table below shows minimum airflow rates for the worst-case plate dissipation (6000 W) with air-flow in two directions. The data reflects an inlet air temperature of 40°C at sea level and applies to operation below 30 MHz. If the tube is used above this frequency additional cooling may be required because of increased rf losses that occur at VHF.

Airflow Direction	Anode Dissipation Watts	Airflow CFM	Approximate Pressure Drop in H ₂ O
Plate to Base	4500	250	1.0
	5000	300	1.2
	6000	400	1.5
Base to Plate	5000	145	.22
	6000	205	.40

At higher altitudes increased airflow is required; in this case both the airflow and pressure drop values shown must be increased by the following factors: 5000 feet x 1.20; 10,000 feet x 1.46. Additional cooling of the tube base may be required especially if the plate cooling air is not directed past the base first; the preferred configuration is airflow is in the base-to-plate direction, although cooling air supplied in the alternate direction is permissible if of the proper flow rate.

Cooling air should be filtered to remove particles of foreign matter that may become embedded in the plate cooling fins and impair cooling efficiency. The main ceramic vacuum envelope in this tube is glazed to allow easy cleaning in the event any particulate matter collects on this surface; this

procedure should be performed regularly in industrial applications where dust or particles are generated in the environment.

The designer is cautioned that the cooling recommendations shown are absolute values for inlet air and temperature rise conditions shown with no safety factor; it is considered good engineering practice to allow additional air flow for conservatism and to make allowance for variables such as dirty air filters, dirty plate cooling fins, pressure losses in air ducting, etc.

Temperature-sensitive paints are available which will allow a check of temperatures before any design is finalized. EIMAC Application Bulletin AB-20, TEMPERATURE MEASUREMENTS WITH EIMAC POWER TUBES, covers this subject in detail and is available on request.

ABSOLUTE MAXIMUM RATINGS - Values shown for each type of service are based on the "absolute system" and are not to be exceeded under any service conditions. These ratings are limiting values outside which serviceability of the tube may be impaired. In order not to exceed absolute ratings the equipment designer has the responsibility of determining an average design value for each rating below the absolute value of that rating by a safety factor so that the absolute values will never be exceeded under any usual conditions of supply-voltage variation, load variation, or manufacturing variation in the equipment itself. It does not necessarily follow that combinations of absolute maximum ratings can be attained simultaneously.

FILAMENT OPERATION - With a new tube, or one that has been in storage for some period of time, operation with filament voltage only applied for a period of 30 to 60 minutes is recommended before full operation begins. This allows the active getter material mounted within the filament structure to absorb any residual gas molecules which have accumulated during storage. Once normal operation has been established a minimum filament warm-up time of five seconds is normally sufficient before commencing operation at full power.



Eimac Application Bulletin #18, EXTENDING TRANSMITTER TUBE LIFE, gives information on the effect of filament voltage on life expectancy.

Filament voltage should be measured at the tube base, using a known-accurate (preferably plus or minus one percent) rms-responding meter. Variation in filament voltage should be limited to no more than +/- five percent for consistent tube performance.

LOAD FAULTS – In self-excited oscillators large load variations or faults can cause potentially dangerous changes in tube efficiency, which in turn can increase plate dissipation to a very high level. If this occurs tube damage can result even though plate current is near the normal operating value. The circuit designer is therefore cautioned to suitably proportion the circuit constants to minimize this effect, and to be sure cooling airflow is adequate to handle worst-case dissipation conditions. New system designs often incorporate a thermal detection device in the exhaust airflow to remove power from the tube in the case of fault conditions.

GRID OPERATION – The maximum no-load grid current rating is 1.0 ampere dc. This value should not be exceeded except during tuning for very short periods, and over-current protection in the grid circuit should be provided. In industrial heating service with varying loads, grid current should be monitored continuously with a dc current meter. The maximum grid dissipation rating is 300 Watts, determined approximately by the product of the dc grid current and the peak positive grid voltage. A protective spark-gap device should be connected between the grid and the cathode to guard against excessive voltage.

FAULT PROTECTION - In addition to normal cooling interlocks and a plate over-current interlock, it is good practice to protect the tube from internal damage which could result from occasional arcing at high plate voltage. In all cases some protective resistance, at least 10 Ohms, should be used in series with the tube plate to absorb power supply stored energy in case an arc should occur. An electronic crowbar, which will discharge power supply capacitors in a few microseconds after the start of an arc, may be required. The test for each electrode supply is to short each electrode to ground, one at a time, through a vacuum relay switch and a 6-inch length of #30 AGW copper

wire. The wire will remain intact if protection is adequate. Eimac Application Bulletin #17, FAULT PROTECTION, contains considerable detail and is available upon request.

INTERELECTRODE CAPACITANCE - The actual internal interelectrode capacitance of a tube is influenced by many variables in most applications, such as stray capacitance to the chassis, capacitance added by the socket used, stray capacitance between tube terminals, and wiring effects. To control the actual capacitance values within the tube, as the key component involved, the industry and the Military Services use a standard test procedure as described in Electronic Industries Association Standard RS-191. This requires the use of specially constructed test fixtures, which effectively shield all external tube leads from each other and eliminates any capacitance reading to "ground". The test is performed on a cold tube, however in the case of the 3CX4500F3/YU-108 no special shielded fixture is used because of the length of the filament leads. Other factors being equal, controlling internal tube capacitance in this way normally assures good interchangeability of tubes over a period of time, even with tubes made by different manufacturers. Capacitance values shown in the manufacturer's technical data, or test specifications, normally are taken in accordance with Standard RS-191.

The equipment designer is therefore cautioned to make allowance for the actual capacitance values which will exist in any normal application. Measurements should be taken with mounting which represents approximate final layout if capacitance values are highly significant in the design.

HIGH VOLTAGE - The 3CX4500F3/YU-108 operates at voltages which can be deadly, and the equipment must be designed properly and operating precautions must be followed. Equipment must be designed so that no one can come in contact with high voltages. All equipment must include safety enclosures for high-voltage circuits and terminals, with interlock switches to open the primary circuits of the power supplies and to discharge high-voltage capacitors whenever access doors are opened. Interlock switches must not be bypassed or "cheated" to allow operation with access doors open. Always remember that HIGH VOLTAGE CAN KILL.



RADIO-FREQUENCY RADIATION - Exposure of personnel to rf radiation should be minimized. Personnel should not be permitted in the vicinity of open energized rf generating circuits, or rf transmission systems (waveguides, cables, connectors, etc.) or energized antennas. It is generally accepted that exposure to "high levels" of rf radiation can result in severe bodily injury including blindness. Cardiac pacemakers may be affected.

The effect of prolonged exposure to "low level" rf radiation continues to be a subject of investigation and controversy. While there continues to be support for lower limits, it is generally agreed among official standard-setting groups in the U.S. that prolonged exposure of personnel to rf radiation at frequencies of 10 MHz to 100 GHz should be limited to average power densities of ten milliwatts per square centimeter (10 mW/cm²) or lower, using any possible one tenth of an hour (.1 hour) as the averaging period. It is also generally agreed that exposure should be reduced in working areas where personal heat load is above normal. The 10mW/cm² average level has been adopted by several U.S. Government agencies including the Occupational Safety and

Health Administration (OSHA) as the standard or protection guide for employee work places.

RF energy must be contained properly by shielding and transmission lines. All input and output RF connections, such as cables, flanges and gaskets must be rf leakproof. Never operate a power tube without a properly matched rf energy absorbing load attached. Never look into or expose any part of the body to an antenna or open rf generating tube or circuit or rf transmission system while it is energized. Monitor the tube and rf system for rf radiation leakage at regular intervals and after servicing.

HOT SURFACES - Air-cooled surfaces and other parts of tubes can reach temperatures of several hundred degrees C and cause serious burns if touched for several minutes after all power is removed.

SPECIAL APPLICATIONS - If it is desired to operate this tube under conditions widely different from those given here, contact the Application Engineering Dept., CPI Eimac Division, San Carlos, Calif. 94070 U.S.A. for information and recommendations.

OPERATING HAZARDS

Proper use and safe operating practices with respect to power tubes are the responsibility of equipment manufacturers and users of such tubes. All persons who work with and are exposed to power tubes, or equipment that utilizes such tubes, must take precautions to protect themselves against possible serious bodily injury. **DO NOT BE CARELESS AROUND SUCH PRODUCTS.**

The operation of this tube may involve the following hazards, any one of which, in the absence of safe operating practices and precautions, could result in serious harm to personnel.

HIGH VOLTAGE – Normal operating voltages can be deadly. Remember the HIGH VOLTAGE CAN KILL.

LOW-VOLTAGE HIGH-CURRENT CIRCUITS - Personal jewelry, such as rings, should not be worn when working with filament contacts or connectors as a short circuit can produce very high current and melting, resulting in severe burns.

RF RADIATION – Exposure to strong rf fields should be avoided, even at relatively low frequencies. **CARDIAC PACEMAKERS MAY BE AFFECTED.**

HOT SURFACES – Surfaces of tubes can reach temperatures of several hundred °C and cause serious burns if touched for several minutes after all power is removed.

Please review the detailed Operating Hazards sheet enclosed with each tube, or request a copy from CPI, Eimac Division Application Engineering at 1-650-592-1221.

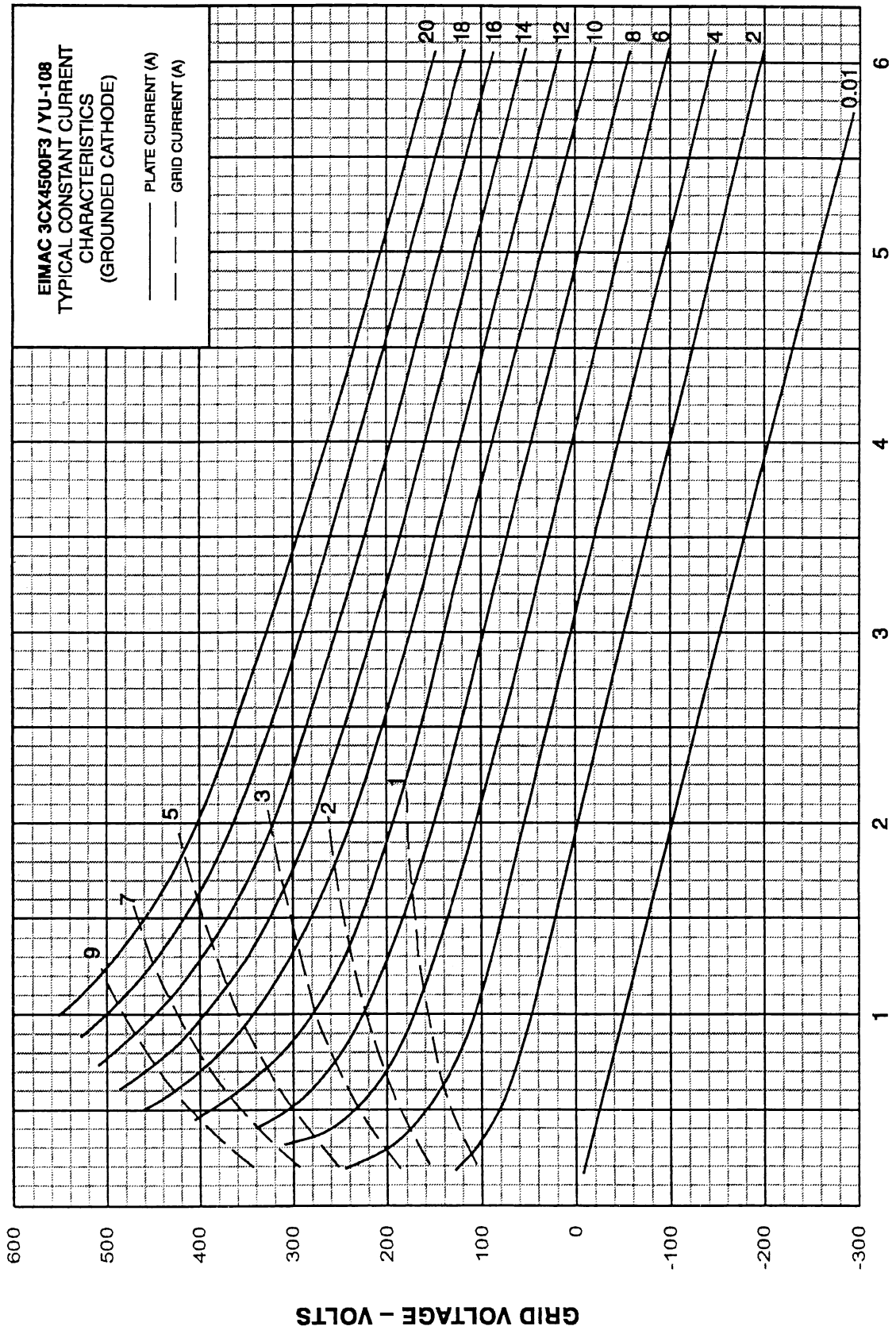
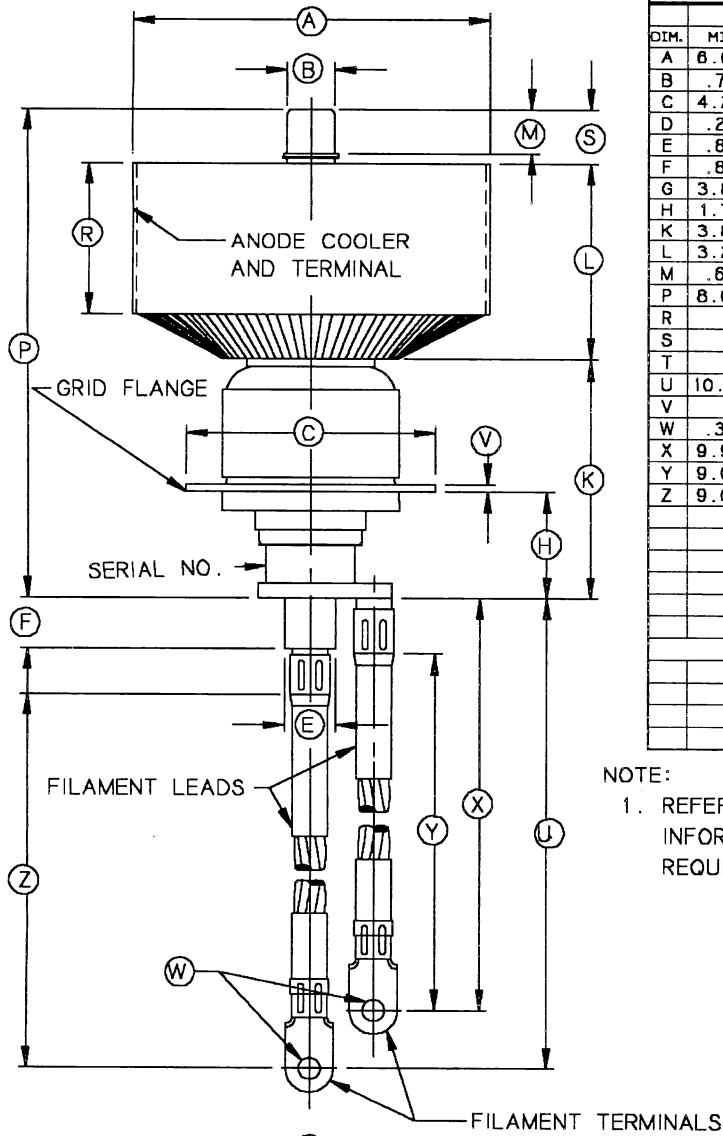

PLATE VOLTAGE - KILOVOLTS

GRID VOLTAGE - VOLTS



DIMENSIONAL DATA						
DIM.	INCHES			MILLIMETERS		
	MIN.	MAX.	REF.	MIN.	MAX.	REF.
A	6.000	6.125		152.40	155.58	
B	.781	.843		19.80	21.40	
C	4.230	4.255		107.40	108.10	
D	.230	.265		5.84	6.73	
E	.859	.890		21.80	22.60	
F	.812	.937		20.60	21.20	
G	3.855	3.885		97.90	98.70	
H	1.703	1.953		43.30	49.60	
K	3.875	4.250		98.40	107.90	
L	3.290	3.375		83.60	85.70	
M	.687	.812		17.50	20.60	
P	8.000	9.000		203.2	228.60	
R			2.625			66.70
S			.900			22.90
T			30°			30°
U	10.937	11.437		277.80	290.50	
V			.125			3.17
W	.385	.395		9.78	10.10	
X	9.937	10.437		252.40	265.10	
Y	9.000	9.500		228.60	241.30	
Z	9.000	9.500		228.60	241.30	

NOTE:

1. REFERENCE DIMENSIONS ARE FOR INFORMATION ONLY AND ARE NOT REQUIRED FOR INSPECTION PURPOSES.

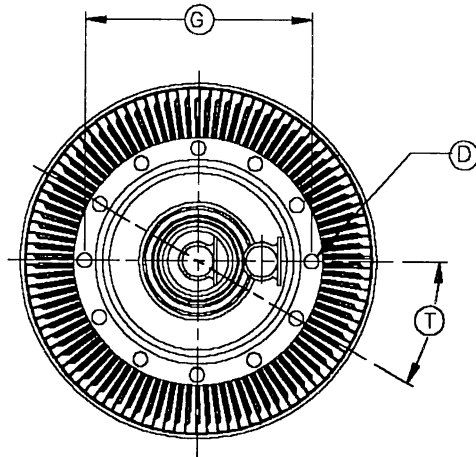



3CX4500F3/YU-108



301 Industrial Road, San Carlos, CA 94070 • Tel: 650-592-1221 • Fax: 650-592-9988
03/03 Printed in USA.