

Eitel-McCullough, Inc.

SAN BRUNO, CALIFORNIA

450TL

MEDIUM-MU TRIODE
MODULATOR
OSCILLATOR
AMPLIFIER

The Eimac 450TL is a medium-mu power triode having a maximum plate dissipation rating of 450 watts, and is intended for use as an amplifier, oscillator and modulator. It can be used at its maximum ratings at frequencies as high as 40-Mc.

Cooling of the 450TL is accomplished by radiation from the plate, which operates at a visible red color at maximum dissipation, and by means of air circulation around the envelope.

GENERAL CHARACTERISTICS

► ELECTRICAL

Filament: Thoriated tungsten	
Voltage	7.5 volts
Current	12.0 amperes
Note: Dual connections for each filament lead are provided within the base of the tube (see basing diagram). Corresponding socket terminals must be connected in parallel to provide proper distribution of filament and R-F charging currents.	
Amplification Factor (Average)	18
Direct Interelectrode Capacitances (Average)	
Grid-Plate	4.5 $\mu\mu\text{f}$
Grid-Filament	6.8 $\mu\mu\text{f}$
Plate-Filament	0.8 $\mu\mu\text{f}$
Transconductance ($i_b=500\text{ma}$, $E_b=4000\text{v}$, $e_c=-75\text{v}$.)	5000 μmhos
Frequency for Maximum Ratings	40-Mc.

► MECHANICAL

Base	Special 4 pin, No. 5002B
Basing	RMA type 4AQ
Mounting	Vertical, base down or up
Cooling	Radiation and air circulation

Note: Adequate ventilation or air cooling must be provided so that the seals and envelope do not exceed 200°C under operating conditions.

Socket Johnson Type No. 211 or National Type No. XM50 or equivalent.

Recommended Heat Dissipating Connectors:

Plate	Eimac HR-8
Grid	Eimac HR-8

Note: The grid terminal of the 450TL is now .560" in diameter. To accommodate existing equipment designed for the older style 450TL having .098" diameter grid terminals, an adapter pin is provided with the newer tubes. This adapter pin is threaded so that it may be removed from the grid terminal of the tube. The small grid terminal, if used, requires an HR-4 heat dissipating connector. (See outline drawing.)

Maximum Overall Dimensions:

Length	12.625 inches
Diameter	5.125 inches
Net weight	1.3 pounds
Shipping weight (Average)	5.6 pounds

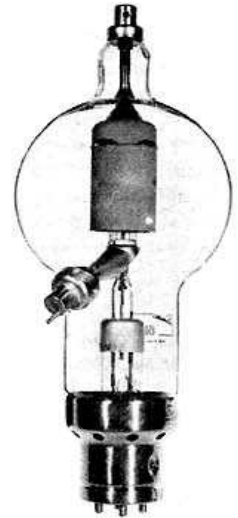

► AUDIO FREQUENCY POWER AMPLIFIER AND MODULATOR

Class AB, (Sinusoidal wave, two tubes unless otherwise specified)

MAXIMUM RATINGS

D-C PLATE VOLTAGE	6000 MAX. VOLTS
MAX-SIGNAL D-C PLATE CURRENT PER TUBE	600 MAX. MA.
PLATE DISSIPATION, PER TUBE	450 MAX. WATTS

TYPICAL OPERATION—2 TUBES

D-C Plate Voltage	3000	4000	5000	Volts
D-C Grid Voltage (approx.)*	-110	-175	-240	Volts
Zero-Signal D-C Plate Current	200	150	120	Ma.
Max-Signal D-C Plate Current	770	675	620	Ma.
Effective Load, Plate-to-Plate	7700	12,800	18,500	Ohms
Peak A-F Grid Input Voltage (per tube)	325	365	430	Volts
Max-Signal Peak Driving Power	40	33	56	Watts
Max-Signal Nominal Driving Power (approx.)	20	17	28	Watts
Max-Signal Plate Power Output	1400	1800	2200	Watts

*Adjust to give stated zero-signal plate current.

► RADIO FREQUENCY POWER AMPLIFIER AND OSCILLATOR

Class-C Telegraphy or FM Telephony (Key-down conditions, per tube).

MAXIMUM RATINGS

D-C PLATE VOLTAGE	6000 MAX. VOLTS
D-C PLATE CURRENT	600 MAX. MA.
PLATE DISSIPATION	450 MAX. WATTS
GRID DISSIPATION	65 MAX. WATTS

TYPICAL OPERATION, PER TUBE*

D-C Plate Voltage	3000	4000	5000	Volts
D-C Grid Voltage	-275	-400	-500	Volts
D-C Plate Current	500	450	450	Ma.
D-C Grid Current	65	53	54	Ma.
Peak R-F Grid Input Voltage	640	740	870	Volts
Driving Power (approx.)	38	35	42	Watts
Grid Dissipation	20	13	15	Watts
Plate Power Input	1500	1800	2250	Watts
Plate Dissipation	450	450	450	Watts
Plate Power Output	1050	1350	1800	Watts

*The figures show actual measured tube performance and do not allow for circuit losses.

► PLATE MODULATED RADIO FREQUENCY AMPLIFIER

Class-C Telephony (Carrier conditions, per tube)

MAXIMUM RATINGS

D-C PLATE VOLTAGE	4500 MAX. VOLTS
D-C PLATE CURRENT	500 MAX. MA.
PLATE DISSIPATION	300 MAX. WATTS
GRID DISSIPATION	65 MAX. WATTS

TYPICAL OPERATION, PER TUBE*

D-C Plate Voltage	3000	4000	4500	Volts
D-C Plate Current	380	340	345	Ma.
Total Bias Voltage	-400	-500	-550	Volts
Fixed Bias Voltage	-200	-250	-275	Volts
Grid Resistor	5000	7000	7500	Ohms
D-C Grid Current	40	36	36	Ma.
Peak R-F Grid Input Voltage	700	790	850	Volts
Driving Power	28	29	31	Watts
Grid Dissipation	12	11	11	Watts
Plate Power Input	1150	1360	1550	Watts
Plate Dissipation	300	300	300	Watts
Plate Power Output	850	1060	1250	Watts

*The figures are for one tube operating at maximum plate dissipation as a plate modulated Class-C amplifier. The output figures do not allow for circuit losses.

► Indicates change from sheet dated 9-1-44.

(Effective 10-1-49) Copyright 1949 by Eitel-McCullough, Inc.

APPLICATION

MECHANICAL

Mounting—The 450TL must be mounted vertically, base up or base down. Flexible connecting straps should be provided from the grid and plate terminals to the external grid and plate circuits. The tube must be protected from severe vibration and shock.

Cooling—Provision should be made for ample circulation of air around the 450TL. In the event that the design of the equipment restricts natural circulation, the use of a small fan or centrifugal blower to provide additional cooling for the tube will aid in obtaining maximum tube life. Special heat-dissipating connectors (Eimac HR-8) are available for use on the plate and grid terminals. These connectors help to prolong tube life by reducing the temperature of the seals.

ELECTRICAL

Filament Voltage—For maximum tube life the filament voltage, as measured directly at the filament pins, should be the rated value of 7.5 volts. Unavoidable variations in filament voltage must be kept within the range from 7.03 to 7.88 volts. All four socket terminals should be used, putting two in parallel for each filament connection.

Bias Voltage—Although there is no maximum limit on the bias voltage which may be used on the 450TL, there is little advantage in using bias voltages in excess of those given under "Typical Operation," except in certain very specialized applications. Where bias is obtained by a grid leak, suitable protective means must be provided to prevent excessive plate dissipation in the event of loss of excitation.

Grid Dissipation—The power dissipated by the grid of the 450TL must not exceed 65 watts. Grid dissipation may be calculated from the following expression:

$$P_g = e_{cmp} I_c$$

where P_g = Grid dissipation

e_{cmp} = Peak positive grid voltage, and

I_c = D-c grid current.

e_{cmp} may be measured by means of a suitable peak voltmeter connected between filament and grid.¹ In equipment in which the plate loading varies widely, such as oscillators used for radio-frequency heating, care should be taken to make certain that the grid dissipation does not exceed the maximum rating under any conditions of loading.

Plate Voltage—Except in very special applications, the plate supply voltage for the 450TL should not exceed 6000 volts. In most cases there is little advantage in using plate-supply voltages higher than those given under "Typical Operation" for the power output desired.

Plate Dissipation—Under normal operating conditions, the power dissipated by the plate of the 450TL should not be allowed to exceed 450 watts. At this dissipation the brightness temperature of the plate will appear a red-orange in color. The value of this color is somewhat affected by light from the filament as well as from external sources. Plate dissipation in excess of the maximum rating is permissible for short periods of time, such as during tuning procedures.

¹ For suitable peak v.t.v.m. circuits see, for instance, "Vacuum Tube Ratings," Eimac News, January, 1945. This article is available in reprint form on request.

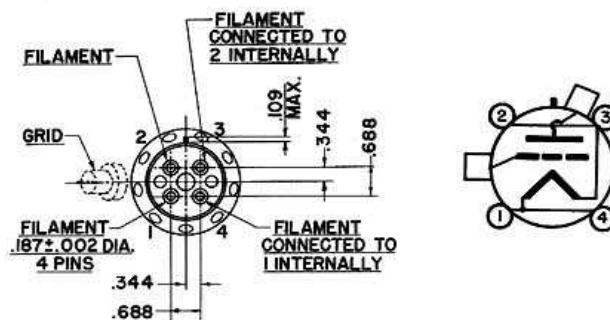
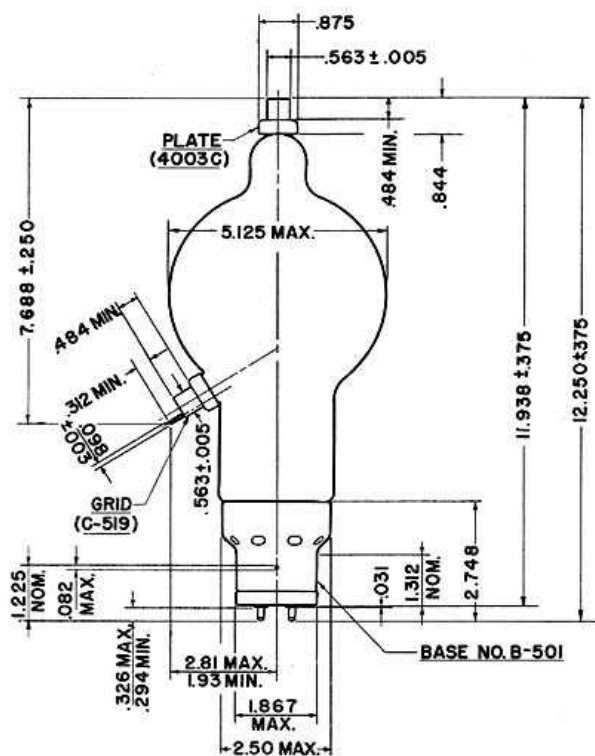

NOTE:—The grid terminal on the new 450TH and TL type tube is now .563" in diameter. To accommodate existing equipment which uses the 450TH or TL tubes with the old style .098" grid terminal, an adaptor pin is provided. This adaptor pin, if not needed, may be removed by unscrewing.

DRIVING POWER vs. POWER OUTPUT

The three charts on this page show the relationship of plate efficiency, power output and grid driving power at plate voltages of 3000, 4000, and 5000 volts. These charts show combined grid and bias losses only. The driving power and power output figures do not include circuit losses. The plate dissipation in watts is indicated by P_p .

Points A, B, and C are identical to the typical Class C operating conditions shown on the first page under 3000, 4000, and 5000 volts respectively.

