



**E I M A C**  
 Division of Varian  
 SAN CARLOS  
 CALIFORNIA

**7203**  
**4CX250B**

**7204**  
**4CX250F**

**RADIAL-BEAM  
 POWER TETRODE**

The 7203/4CX250B and 7204/4CX250F are ceramic/metal forced-air cooled, external-anode radial-beam tetrodes with a maximum plate dissipation rating of 250 watts and a maximum input-power rating of 500 watts. The 7203/4CX250B is designed to operate with a heater voltage of 6.0 volts, while the 7204/4CX250F is designed for operation at a heater voltage of 26.5 volts. Otherwise, the two tube types have identical characteristics.

**GENERAL CHARACTERISTICS<sup>1</sup>**

**ELECTRICAL**

Cathode: Oxide Coated, Unipotential

Heater: Voltage (4CX250B) . . . . .	6.0 ± 0.3 V
Current, at 6.0 volts . . . . .	2.6 A
Cathode-Heater Potential, maximum . . . . .	±150 V
Heater: Voltage (4CX250F) . . . . .	26.5 ± 1.3 V
Current, at 26.5 volts . . . . .	0.56 A
Cathode-Heater Potential, maximum. . . . .	±150 V

Amplification Factor (Average):

Grid to Screen . . . . .	5
--------------------------	---

Direct Interelectrode Capacitances (Grounded cathode)<sup>2</sup>

Input . . . . .	15.7 pF
Output . . . . .	4.5 pF
Feedback . . . . .	0.04 pF

Direct Interelectrode Capacitances (grounded grid and screen)<sup>2</sup>

Input . . . . .	13 pF
Output . . . . .	4.5 pF
Feedback . . . . .	0.01 pF

Frequency of Maximum Rating:

CW . . . . .	500 MHz
--------------	---------

1. Characteristics and operating values are based upon performance tests. These figures may change without notice as the result of additional data or product refinement. EIMAC Division of Varian should be consulted before using this information for final equipment design.

2. In Shielded Fixture.

**MECHANICAL**

Maximum Overall Dimensions:

Length . . . . .	2.46 in; 62.5 mm
Diameter . . . . .	1.64 in; 41.7 mm
Net Weight . . . . .	4 oz; 113 gm
Operating Position . . . . .	Any





Maximum Operating Temperature:

Ceramic/Metal Seals . . . . .	250°C
Anode Core . . . . .	250°C
Cooling . . . . .	Forced Air
Base . . . . .	Special 9-pin JEDEC-B8-236
Recommended Socket . . . . .	EIMAC SK-600 Series
Recommended Chimney . . . . .	EIMAC SK-600 Series

RADIO FREQUENCY LINEAR AMPLIFIER  
GRID DRIVEN (SSB)

Class AB<sub>1</sub>

MAXIMUM RATINGS

DC PLATE VOLTAGE . . . . .	2000 VOLTS
DC SCREEN VOLTAGE . . . . .	400 VOLTS
DC GRID VOLTAGE . . . . .	-250 VOLTS
DC PLATE CURRENT . . . . .	0.25 AMPERE
PLATE DISSIPATION . . . . .	250 WATTS
SCREEN DISSIPATION . . . . .	12 WATTS
GRID DISSIPATION . . . . .	2 WATTS

TYPICAL OPERATION (Frequencies to 175 MHz)

Class AB<sub>1</sub>, Grid Driven, Peak Envelope or Modulation Crest Conditions

Plate Voltage . . . . .	1000	1500	2000	Vdc
Screen Voltage . . . . .	350	350	350	Vdc
Grid Voltage 1 . . . . .	-55	-55	-55	Vdc
Zero-Signal Plate Current . . . . .	100	100	100	mAdc
Single Tone Plate Current . . . . .	250	250	250	mAdc
Two-Tone Plate Current . . . . .	190	190	190	mAdc
Single-Tone Screen Current <sup>2</sup> . . . . .	10	8	5	mAdc
Two-Tone Screen Current <sup>2</sup> . . . . .	2	-1	-2	mAdc
Single-Tone Grid Current <sup>2</sup> . . . . .	0	0	0	mAdc
Peak rf Grid Voltage <sup>2</sup> . . . . .	50	50	50	v
Plate Output Power . . . . .	120	215	300	W
Resonant Load Impedance . . . . .	2000	3000	4000	Ω

1. Adjust to specified zero-signal dc plate current.
2. Approximate value.

RADIO FREQUENCY LINEAR AMPLIFIER  
GRID DRIVEN, CARRIER CONDITIONS

Class AB<sub>1</sub>

MAXIMUM RATINGS

DC PLATE VOLTAGE . . . . .	2000 VOLTS
DC SCREEN VOLTAGE . . . . .	400 VOLTS
DC GRID VOLTAGE . . . . .	-250 VOLTS
DC PLATE CURRENT . . . . .	0.25 AMPERE
PLATE DISSIPATION . . . . .	250 WATTS
SCREEN DISSIPATION . . . . .	12 WATTS
GRID DISSIPATION . . . . .	2 WATTS

TYPICAL OPERATION (Frequencies to 175 MHz)

Class AB<sub>1</sub>, Grid Driven

Plate Voltage . . . . .	1000	1500	2000	Vdc
Screen Voltage . . . . .	350	350	350	Vdc
Grid Voltage 1 . . . . .	-55	-55	-55	Vdc
Zero-Signal Plate Current . . . . .	100	100	100	mAdc
Carrier Plate Current . . . . .	150	150	150	mAdc
Carrier Screen Current . . . . .	-3	-4	-4	mAdc
Peak rf Grid Voltage <sup>2</sup> . . . . .	25	25	25	v
Plate Output Power . . . . .	30	50	65	W

1. Adjust to specified zero-signal dc plate current
2. Approximate value.

RADIO FREQUENCY POWER AMPLIFIER  
OR OSCILLATOR

Class C Telegraphy or FM Telephony  
(Key-Down Conditions)

MAXIMUM RATINGS

DC PLATE VOLTAGE . . . . .	2000 VOLTS
DC SCREEN VOLTAGE . . . . .	300 VOLTS
DC GRID VOLTAGE . . . . .	-250 VOLTS
DC PLATE CURRENT . . . . .	0.25 AMPERE
PLATE DISSIPATION . . . . .	250 WATTS
SCREEN DISSIPATION . . . . .	12 WATTS
GRID DISSIPATION . . . . .	2 WATTS

TYPICAL OPERATION (Frequencies to 175 MHz) | 500 MHz<sup>2</sup>

Plate Voltage . . . . .	500	1000	1500	2000	2000	Vdc
Screen Voltage . . . . .	250	250	250	250	300	Vdc
Grid Voltage . . . . .	-90	-90	-90	-90	-90	Vdc
Plate Current . . . . .	250	250	250	250	250	mAdc
Screen Current <sup>1</sup> . . . . .	45	38	21	19	10	mAdc <sup>2</sup>
Grid Current <sup>1</sup> . . . . .	35	31	28	26	25	mAdc <sup>2</sup>
Peak rf Grid Voltage <sup>1</sup> . . . . .	114	114	112	112	---	v
Measured Driving Power <sup>1</sup> . . . . .	4.0	3.5	3.2	2.9	---	W
Plate Input Power . . . . .	125	250	375	500	500	W
Plate Output Power . . . . .	70	190	280	390	225	W <sup>2</sup>
Heater Voltage . . . . .	6.0	6.0	6.0	6.0	5.5	V

1. Approximate value.
2. Measured values for a typical cavity amplifier circuit.



**PLATE MODULATED RADIO FREQUENCY POWER AMPLIFIER-GRID DRIVEN**

Class C Telephony (Carrier Conditions)

**MAXIMUM RATINGS**

DC PLATE VOLTAGE	1500 VOLTS
DC SCREEN VOLTAGE	300 VOLTS
DC GRID VOLTAGE	-250 VOLTS
DC PLATE CURRENT	0.20 AMPERE
PLATE DISSIPATION <sup>1</sup>	165 WATTS
SCREEN DISSIPATION <sup>2</sup>	12 WATTS
GRID DISSIPATION <sup>2</sup>	2 WATTS

1. Corresponds to 250 watts at 100% sine-wave modulation.
2. Average, with or without modulation.

**TYPICAL OPERATION (Frequencies to 175 MHz)**

Plate Voltage	500	1000	1500	Vdc
Screen Voltage	250	250	250	Vdc
Grid Voltage	-100	-100	-100	Vdc
Plate Current	200	200	200	mAdc
Screen Current	31	22	20	mAdc
Grid Current	15	14	14	mAdc
Peak rf Grid Voltage	118	117	117	v
Calculated Driving Power	1.8	1.7	1.7	W
Plate Input Power	100	200	300	W
Plate Output Power	60	145	235	W

3. Approximate value.

**AUDIO FREQUENCY POWER AMPLIFIER OR MODULATOR**

Class AB, Grid Driven (Sinusoidal Wave)

**MAXIMUM RATINGS (Per Tube)**

DC PLATE VOLTAGE	2000 VOLTS
DC SCREEN VOLTAGE	400 VOLTS
DC GRID VOLTAGE	-250 VOLTS
DC PLATE CURRENT	0.25 AMPERE
PLATE DISSIPATION	250 WATTS
SCREEN DISSIPATION	12 WATTS
GRID DISSIPATION	2 WATTS

1. Approximate value.
2. Per Tube.

**TYPICAL OPERATION (Two Tubes)**

Plate Voltage	1000	1500	2000	Vdc
Screen Voltage	350	350	350	Vdc
Grid Voltage 1/3	-55	-55	-55	Vdc
Zero-Signal Plate Current	200	200	200	mAdc
Max Signal Plate Current	500	500	500	mAdc
Max Signal Screen Current <sup>1</sup>	20	16	10	mAdc
Max Signal Grid Current <sup>1</sup>	0	0	0	mAdc
Peak af Grid Voltage <sup>2</sup>	50	50	50	v
Peak Driving Power	0	0	0	W
Plate Input Power	500	750	1000	W
Plate Output Power	240	430	600	W
Load Resistance (plate to plate)	3500	6200	9500	Ω

3. Adjust to give stated zero-signal plate current.

NOTE: TYPICAL OPERATION data are obtained from direct measurement or by calculation from published characteristic curves. Adjustment of the rf grid voltage to obtain the specified plate current at the specified bias, screen and plate voltages is assumed. If this procedure is followed, there will be little variation in output power when the tube is changed, even though there may be some variation in grid and screen current. The grid and screen currents which result when the desired plate current is obtained are incidental and vary from tube to tube. These current variations cause no difficulty so long as the circuit maintains the correct voltage in the presence of the variations in current. In the case of Class C Service, if grid bias is obtained principally by means of a grid resistor, the resistor must be adjustable to obtain the required bias voltage when the correct rf grid voltage is applied.

**RANGE VALUES FOR EQUIPMENT DESIGN**

	<u>Min.</u>	<u>Nom.</u>	<u>Max.</u>	
Heater: 4CX250B Current at 6.0 volts	2.3	---	2.9	A
Heater: 4CX250F Current at 26.5 volts	0.50	---	0.62	A
Cathode Warmup Time	30	60	---	sec.
<b>Interelectrode Capacitances<sup>1</sup>(grounded cathode connection)</b>				
Input	14.2	---	17.2	pF
Output	4.0	---	5.0	pF
Feedback	---	---	0.06	pF
<b>Interelectrode Capacitances<sup>1</sup>(grounded grid and screen)</b>				
Input	---	13.0	---	pF
Output	4.0	---	5.0	pF
Feedback	---	0.01	---	pF



## APPLICATION

### MECHANICAL

**MOUNTING** - The 4CX250B and 4CX250F may be operated in any position. An EIMAC Air-System Socket, SK-600 series, or a socket having equivalent characteristics, is required. Sockets are available with or without built-in screen capacitors and may be obtained with either grounded or ungrounded cathode terminals.

**COOLING** - Sufficient forced-air cooling must be provided for the anode, base seals, and body seals to maintain operating temperatures below the rated maximum values. Air requirements to maintain anode core temperatures at 200°C with an inlet air temperature of 50°C are tabulated below. These requirements apply when a socket of the EIMAC SK-600 series and an EIMAC SK-606 chimney are used with air flow in the base to anode direction.

SEA LEVEL			10,000 FEET	
Plate Dissipation(watts)	Air Flow (CFM)	Pressure Drop(In.of water)	Air Flow (CFM)	Pressure Drop(In.of water)
200	5.0	0.52	7.3	0.76
250	6.4	0.82	9.3	1.20

The blower selected in a given application must be capable of supplying the desired airflow at a back pressure equal to the pressure drop shown above plus any drop encountered in ducts and filters. The blower must be designed to deliver the air at the desired altitude.

At 500 MHz or below, base cooling air requirements are satisfied automatically when the tube is operated in an EIMAC Air-System Socket and the recommended air flow rates are used. Experience has shown that if reliable long life operation is to be obtained, the cooling air flow must be maintained during standby periods when only the heater voltage is applied to the tube. The anode cooler should be inspected periodically and cleaned when necessary to remove any dirt which might interfere with effective cooling.

**VIBRATION** - These tubes are capable of satisfactorily withstanding ordinary shock and vibration, such as encountered in shipment and normal handling. The tubes will function well in automobile and truck mobile installations and similar environments. However, when shock and vibration more severe than this are expected, it is suggested that the EIMAC 4CX300A or 4CX250R be employed.

### ELECTRICAL

**HEATER** - The rated heater voltage for the 4CX250B and 4CX250F is 6.0 volts and 26.5 volts, respectively, and the voltage should be maintained as closely as practicable. Short-time changes of  $\pm 10\%$  will not damage the tube, but variations in performance must be expected. The heater voltage must be maintained within  $\pm 5\%$  to minimize these variations and to obtain maximum tube life.

At frequencies above approximately 300 MHz transit-time effects begin to influence the cathode temperature. The amount of driving power diverted to heating the cathode by back-bombardment will depend upon frequency, plate current, and driving power. When the tube is driven to maximum input as a class-C amplifier, the heater voltage should be reduced according to the table below;

Frequency MHz	4CX250B	4CX250F
300 and lower	6.00 volts	26.5 volts
301 to 400	5.75 volts	25.3 volts
401 to 500	5.50 volts	24.3 volts

**CATHODE OPERATION** - The oxide coated unipotential cathode must be protected against excessively high emission currents. The maximum rated dc input current is 200 mA for plate-modulated operation and 250 mA for all other types of operation except pulse.

The cathode is internally connected to the four even-numbered base pins and all four of the corresponding socket terminals should be used to make connection to the external circuits. At radio frequencies it is important to keep the cathode leads short and direct and to use conductors with large areas to minimize the inductive reactances in series with the cathode leads.

It is recommended that rated heater voltage be applied for a minimum of 30 seconds before other operating voltages are applied. Where the circuit design requires the cathode and heater to be operated at different potentials, the rated maximum heater-to-cathode voltage is 150 volts regardless of polarity.

**GRID OPERATION** - The maximum rated dc grid bias voltage is -250 volts and the maximum grid dissipation rating is 2.0 watts. In ordinary audio and radio-frequency amplifiers the grid dissipation usually will not approach the maximum rating. At operating frequencies above the 100 MHz region, driving-power requirements for



amplifiers increase noticeably. At 500 MHz as much as 20 watts of driving power may have to be supplied. However, most of the driving power is absorbed in circuit losses other than grid dissipation, so that grid dissipation is increased only slightly. Satisfactory 500 MHz operation of the tube in a stable amplifier is indicated by grid-current values below approximately 15 mA.

The grid voltage required by different tubes may vary between limits approximately 20% above and below the center value, and means should be provided in the equipment to accommodate such variation. It is especially important that variations between individual tubes be compensated when tubes are operated in parallel or push-pull circuits, to assure equal load sharing.

The maximum permissible grid-circuit resistance per tube is 100,000 ohms.

**SCREEN OPERATION** - The maximum rated power dissipation for the screen is 12 watts, and the screen input power should be kept below that level. The product of the peak screen voltage and the indicated dc screen current approximates the screen input power except when the screen current indication is near zero or negative.

In the usual tetrode amplifier, where no signal voltage appears between cathode and screen, the peak screen voltage is equal to the dc screen voltage.

When signal voltages appear between screen and cathode, as in the case of screen-modulated amplifiers or cathode-driven tetrode amplifiers, the peak screen-to-cathode voltage is the sum of the dc screen voltage and the peak ac or rf signal voltage applied to screen or cathode.

Protection for the screen should be provided by an over-current relay and by interlocking the screen supply so that plate voltage must be applied before screen voltage can be applied.

The screen current may reverse under certain conditions and produce negative current indications on the screen milliammeter. This is a normal characteristic of most tetrodes. The screen power supply should be designed with this characteristic in mind so that the correct operating voltage will be maintained on the screen under all conditions. A current path from screen to cathode must be provided by a bleeder resistor, gaseous voltage regulator tubes, or an electron

tube *shunt* regulator connected between screen and cathode and arranged to pass approximately 15 milliamperes per connected screen. An electron tube *series* regulator can be used only when an equate bleeder resistor is provided.

Self-modulation of the screen in plate-modulated tetrode amplifiers using these tubes may not be satisfactory because of the screen-voltage screen-current characteristics. Screen modulation from a tertiary winding on the modulation transformer or by means of a small separate modulator tube will usually be more satisfactory. Screen-voltage modulation factors between 0.75 and 1.0 will result in 100% modulation for plate-modulated rf amplifiers using the 4CX250B or 4CX250F.

**PLATE OPERATION** - The maximum rated plate dissipation power is 250 watts. In plate-modulated applications the carrier plate dissipation power must be limited to 165 watts to avoid exceeding the plate dissipation rating with 100% sine wave modulation. The maximum dissipation rating may be exceeded for brief periods during circuit adjustment without damage to the tube.

**MULTIPLE OPERATION** - Tubes operating in parallel or push-pull must share the load equally. It is good engineering practice to provide individual metering and individual adjustment of bias or screen voltage to equalize the inputs.

Where overload protection is provided, it should be capable of protecting the surviving tube(s) in the event that one tube fails.

**VHF OPERATION** - The 4CX250B and 4CX250F are suitable for use in the VHF region. Such operation should be conducted with heavy plate loading, minimum bias, and the lowest driving power consistent with satisfactory performance. It is often preferable to operate at a sacrifice in efficiency to obtain increased tube life.

**SPECIAL APPLICATIONS**-If it is desired to operate these tubes under conditions widely different from those given here, write to Application Engineering Dept., EIMAC Division of Varian, San Carlos, Calif. 94070 for information and recommendations.



**EIMAC 4CX250B & 4CX250F**

**TYPICAL**

**CONSTANT-CURRENT CHARACTERISTICS**

SCREEN VOLTAGE, 350 VOLTS

- PLATE CURRENT—AMPERES
- - - SCREEN CURRENT—AMPERES
- · - · - GRID CURRENT—AMPERES

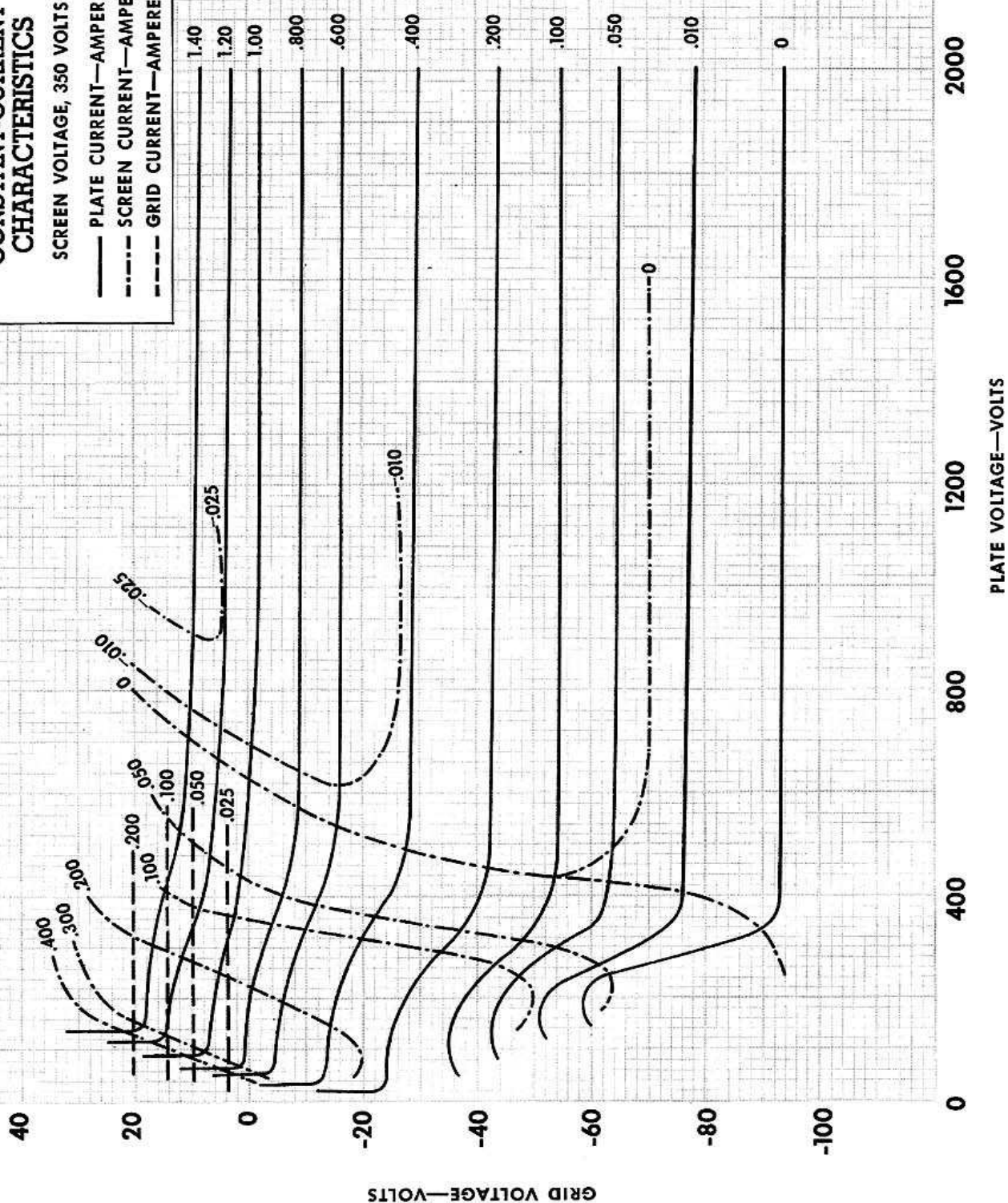



**EIMAC 4CX250B & 4CX250F**  
**TYPICAL**  
**CONSTANT-CURRENT**  
**CHARACTERISTICS**  
SCREEN VOLTAGE, 250 VOLTS

- PLATE CURRENT—AMPERES
- - - SCREEN CURRENT—AMPERES
- · - · - GRID CURRENT—AMPERES

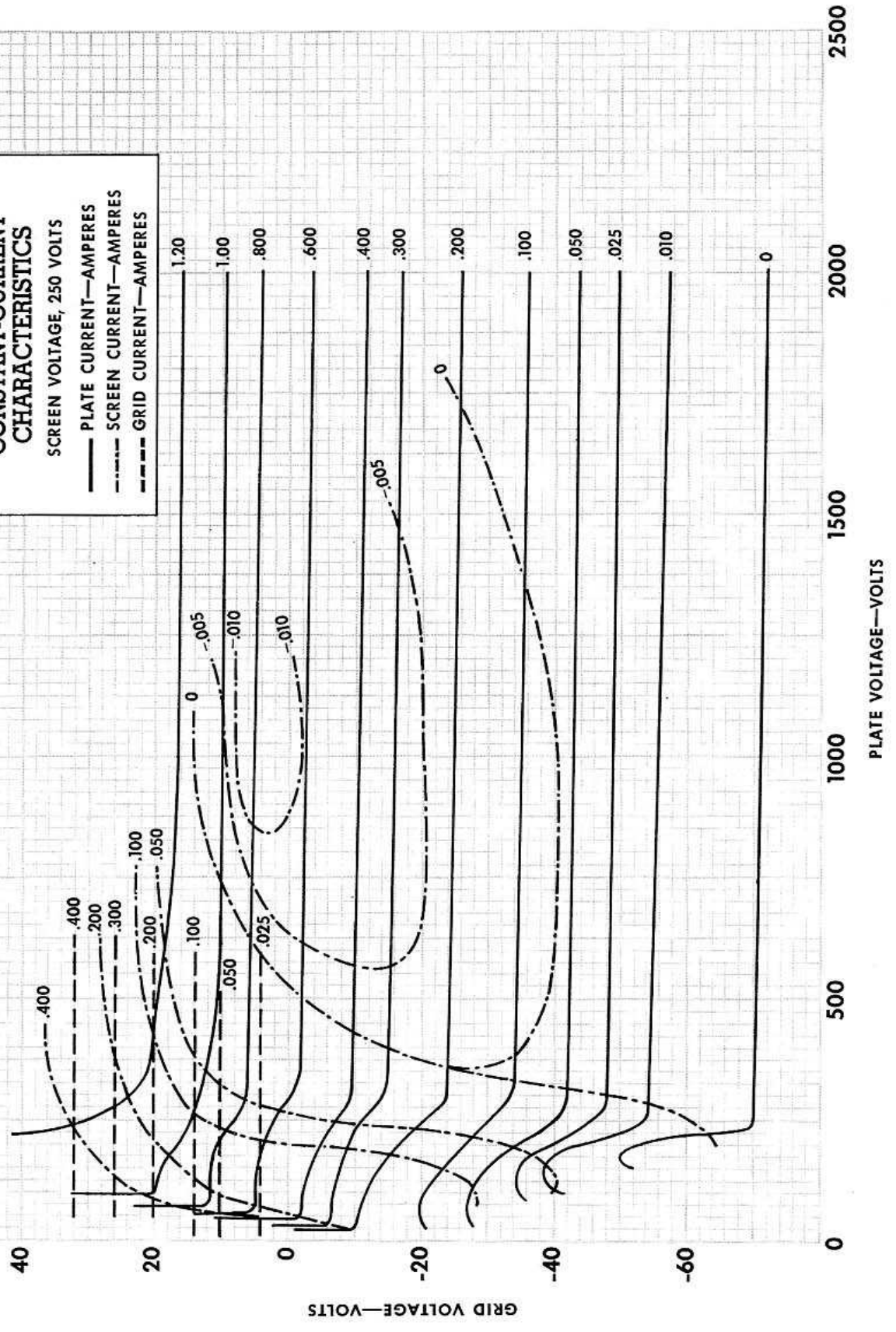



**PIN DESIGNATION**

PIN NO. 1	SCREEN GRID
PIN NO. 2	CATHODE
PIN NO. 3	HEATER
PIN NO. 4	CATHODE
PIN NO. 5	I.C. DO NOT USE FOR EXTERNAL CONNECTION.
PIN NO. 6	CATHODE
PIN NO. 7	HEATER
PIN NO. 8	CATHODE
CENTER PIN-CONTROL GRID	

DIMENSIONAL DATA				
DIM.	INCHES		MILLIMETERS	
	MIN.	MAX.	MIN.	MAX.
A	2.342	2.464	59.03	62.59
B	1.610	1.640	40.89	41.66
C	1.810	1.910	45.97	48.51
D	0.750	0.810	19.05	20.57
E	0.710	0.790	18.03	20.07
F	--	1.406	--	35.71
G	0.187	--	4.75	--
H	BASE: B8-236 (JEDEC DESIGNATION)			
J	0.559	0.573	14.20	14.55
K	0.240	--	6.10	--

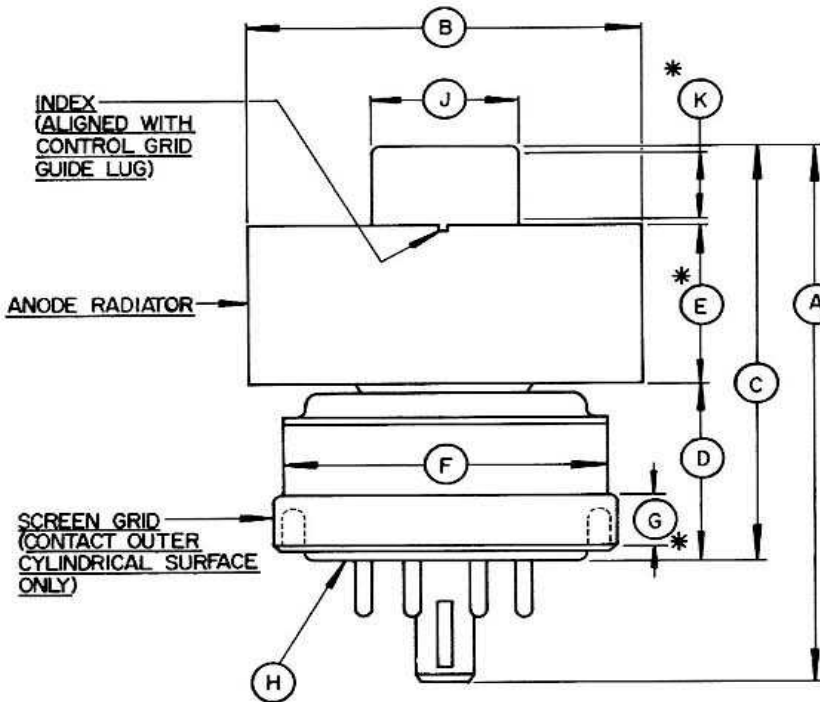

**NOTES:**

1. REF DIMS. ARE FOR INFO ONLY AND ARE NOT REQD. FOR INSPECTION PURPOSES.
2. (\*) CONTACT SURFACES.