

*Eitel*  
**EITEL-McCULLOUGH, INC.**  
 SAN BRUNO, CALIFORNIA

**750TL**  
 (3-750A2)  
**MEDIUM-MU TRIODE**  
 •  
**MODULATOR**  
**OSCILLATOR**  
**AMPLIFIER**

**GENERAL CHARACTERISTICS**

**ELECTRICAL**

Filament: Thoriated tungsten		
Voltage - - - - -	7.5	volts
Current - - - - -	21.0	amperes
Amplification Factor (Average) - - - - -		15
Direct Interelectrode Capacitances (Average)		
Grid-Plate - - - - -	5.8	$\mu\mu\text{f}$
Grid-Filament - - - - -	8.5	$\mu\mu\text{f}$
Plate-Filament - - - - -	1.2	$\mu\mu\text{f}$
Transconductance ( $I_b=1.0$ amp., $E_b=5000$ , $e_c=-100$ )	3500	$\mu\text{mhos}$
Frequency for Maximum Ratings - - - - -		40 mc

**MECHANICAL**

Base - Special 4 pin, (Fits Johnson No. 214 Socket, or equal) No. 5003B	
Basing - - - - -	RMA type 4BD
Maximum Overall Dimensions:	
Length - - - - -	17.0 inches
Diameter - - - - -	7.125 inches
Net weight - - - - -	2.75 pounds
Shipping weight (Average) - - - - -	8.0 pounds

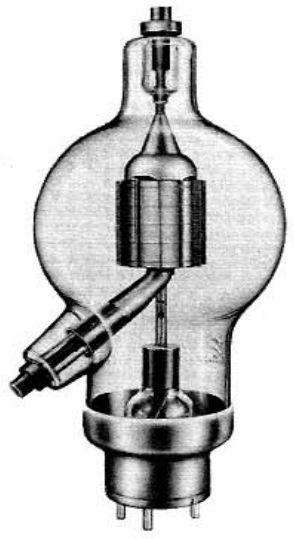

**AUDIO FREQUENCY POWER AMPLIFIER AND MODULATOR**  
**Class B**

	TYPICAL OPERATION—2 TUBES			MAX. RATING	
	4000	5000	6000		
D-C Plate Voltage - - - - -	4000	5000	6000	10000	volts
Max.-Signal D-C Plate Current, per tube* - -	•	•	•	1000	ma.
Plate Dissipation, per tube* - - - - -	•	•	•	750	watts
D-C Grid Voltage (approx.) - - - - -	-200	-285	-350		volts
Peak A-F Grid Input Voltage - - - - -	910	1060	1200		volts
Zero-Signal D-C Plate Current - - - - -	.250	.200	.166		amps.
Max.-Signal D-C Plate Current - - - - -	.950	.860	.834		amps.
Max.-Signal Driving Power (approx.) - - - -	24	23	30		watts
Effective Load, Plate-to-Plate - - - - -	8270	12300	16300		ohms
Max.-Signal Plate Power Output - - - - -	2300	2800	3500		watts

\*Averaged over any sinusoidal audio frequency cycle.

**RADIO FREQUENCY POWER AMPLIFIER AND OSCILLATOR**  
**Class-C \*Telegraphy**  
 (Key down conditions without modulation)

	TYPICAL OPERATION—1 TUBE				MAX. RATING	
	3000	4000	5000	6000		
D-C Plate Voltage - - - - -	3000	4000	5000	6000	10000	volts
D-C Plate Current - - - - -	713	625	600	625	1000	ma.
D-C Grid Current - - - - -	95	69	67	78	125	ma.
D-C Grid Voltage - - - - -	-350	-450	-550	-700		volts
Plate Power Output - - - - -	1390	1750	2250	3000		watts
Plate Input - - - - -	2140	2500	3000	3750		watts
Plate Dissipation - - - - -	750	750	750	750	750	watts
Peak R. F. Grid Input Voltage, (approx.) - -	860	900	1000	1120		volts
Driving Power, (approx.) - - - - -	74	53	61	93		watts

\*The above figures show actual measured tube performance, and do not allow for variations in circuit losses.

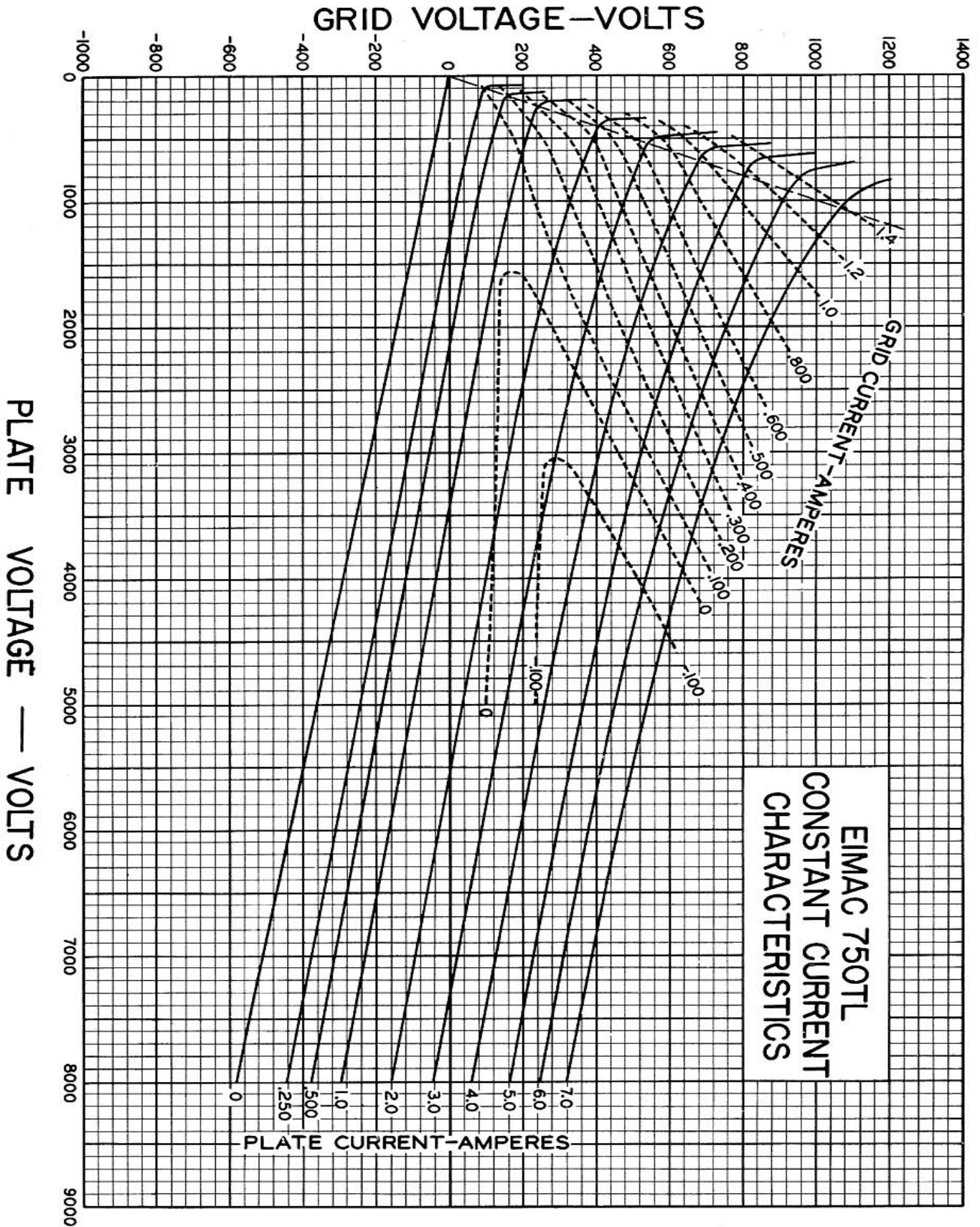

## DRIVING POWER vs. POWER OUTPUT

The three charts on this page show the relationship of plate efficiency, power output and grid driving power at plate voltages of 4000, 5000, and 6000 volts. These charts show combined grid and bias losses only. The driving power and power output figures do not include circuit losses. The plate dissipation in watts is indicated by  $P_p$ . Points A, B, and C are identical to the typical Class C operating conditions shown on the first page under 4000, 5000, and 6000 volts respectively.

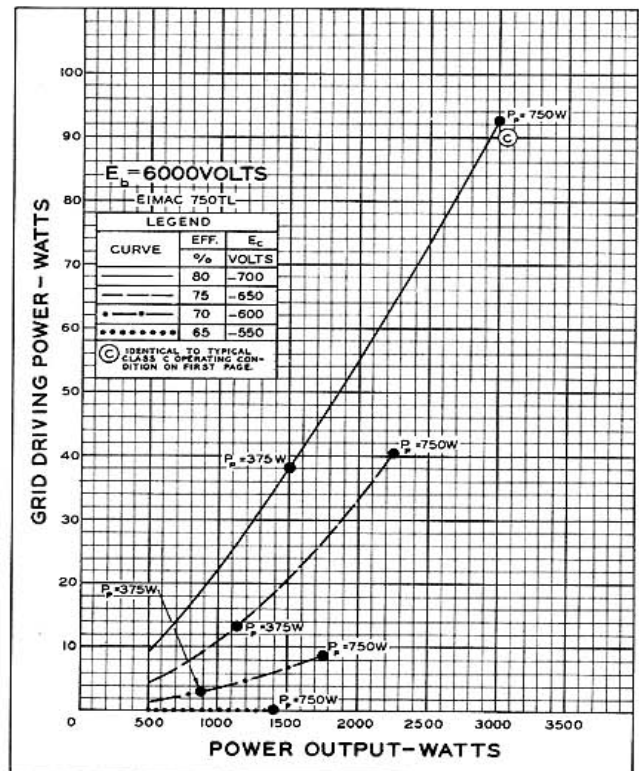
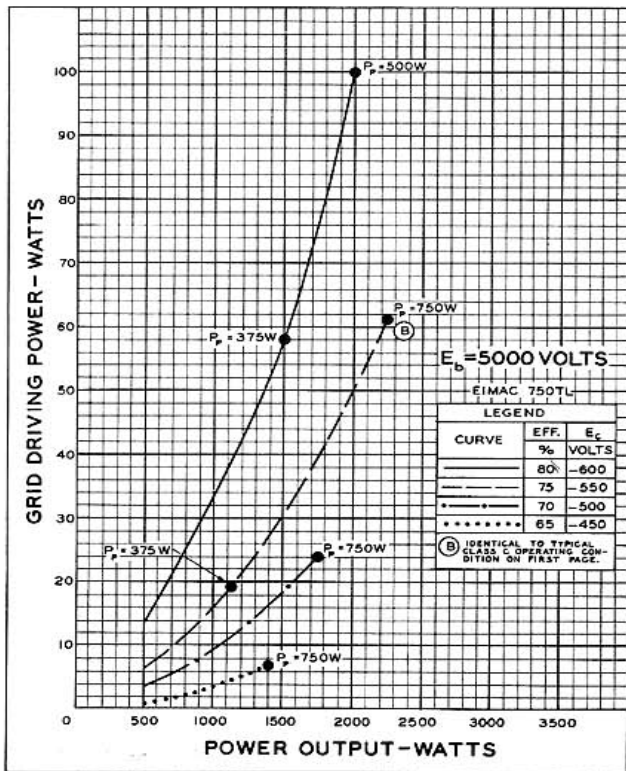
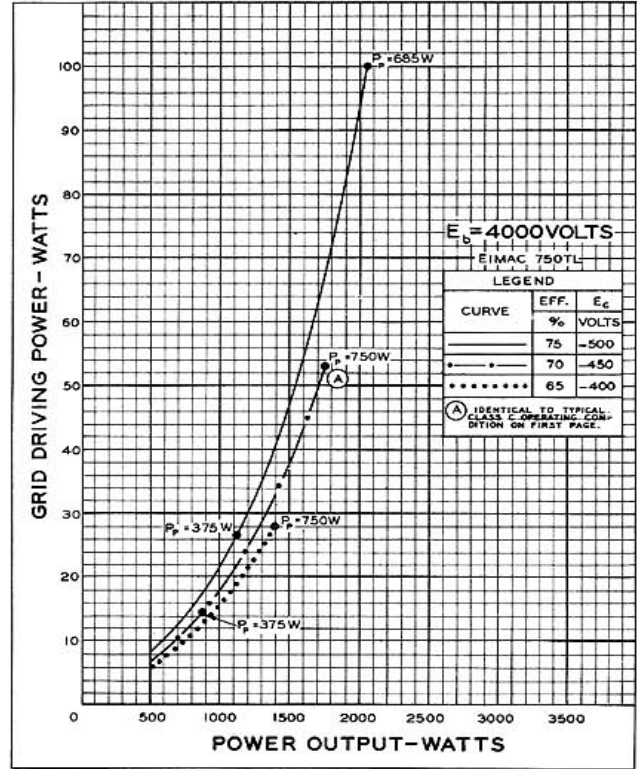

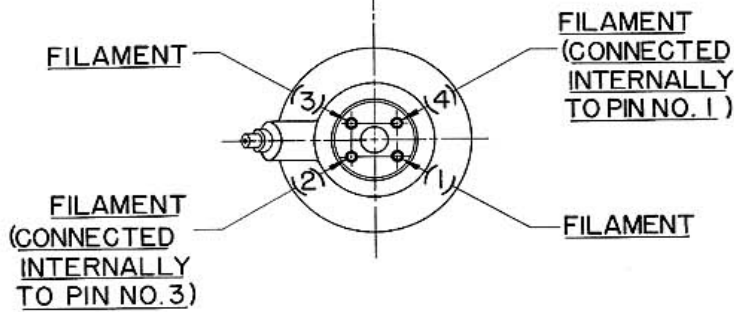
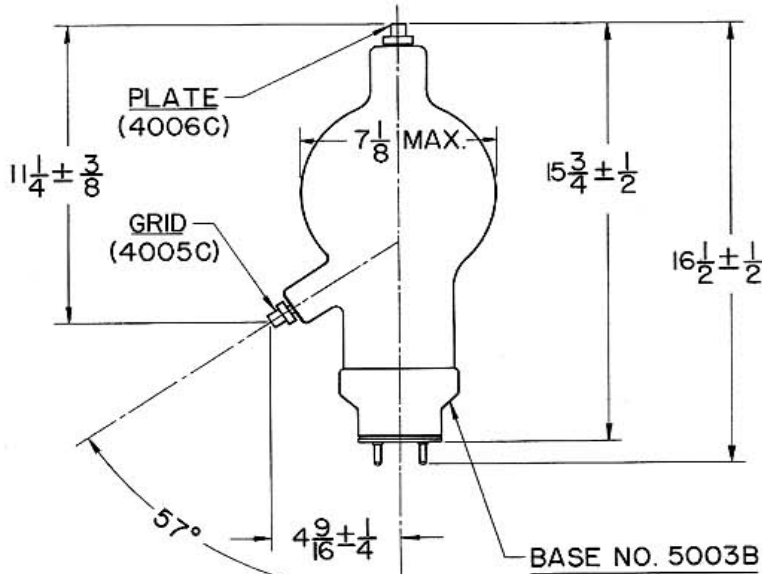

**48D**

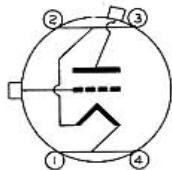

**CAPS**  
 PLATE  
 CAP NO. 4006C

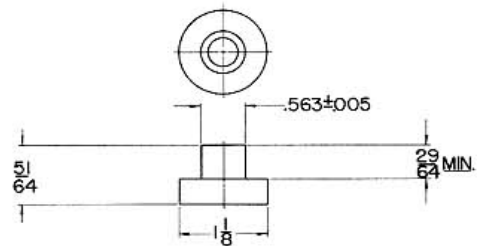

**GRID**  
 CAP NO. 4005C

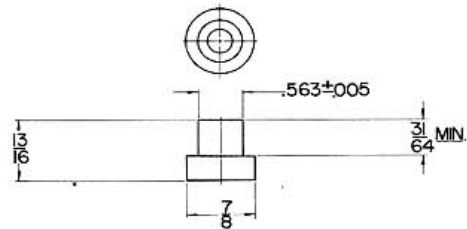

**BASE NO. 5003B**

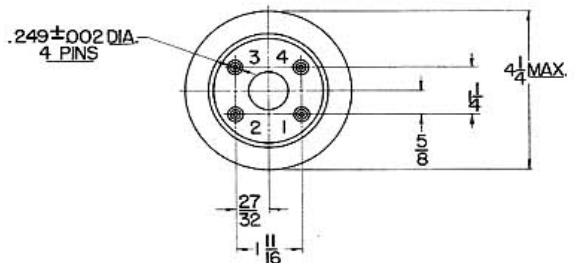
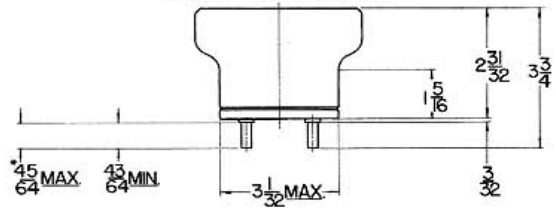

\*ON FINISHED TUBE ADD .060 FOR SOLDER.

## AIR COOLING

Provision should be made for ample circulation of air in the equipment employing this type tube.