

# Eitel-McCullough, Inc.

SAN BRUNO, CALIFORNIA

# 75TL

LOW-MU TRIODE  
MODULATOR  
OSCILLATOR  
AMPLIFIER

The Eimac 75TL is a low-mu, high-vacuum transmitting triode intended for amplifier, oscillator and modulator service. It has a maximum plate dissipation rating of 75 watts. Cooling of the 75TL is accomplished by radiation from the plate, which operates at a visibly red temperature at maximum dissipation, and by air circulation around the envelope.

## GENERAL CHARACTERISTICS

### ELECTRICAL

Filament: Thoriated tungsten	
Voltage	5.0 volts
Current	6.25 amperes
Amplification Factor (Average) <span style="float: right;">12</span>	
Direct Interelectrode Capacitances (Average)	
Grid-Plate	2.4 $\mu\mu\text{fd.}$
Grid-Filament	2.6 $\mu\mu\text{fd.}$
Plate-Filament	0.4 $\mu\mu\text{fd.}$
Transconductance ( $i_b = 225\text{ma.}$ , $E_b = 2500\text{v.}$ , $E_c = -182\text{v.}$ ) <span style="float: right;">3350 <math>\mu\text{mhos}</math></span>	

### MECHANICAL

Base	Medium 4-pin bayonet, ceramic, RMA type M8-078
Basing	RMA type 2M
Cooling	Radiation and air circulation

#### Maximum Overall Dimensions:

Length	7.25 inches
Diameter	2.81 inches
Net weight	3 ounces
Shipping weight (Average)	1.5 pounds

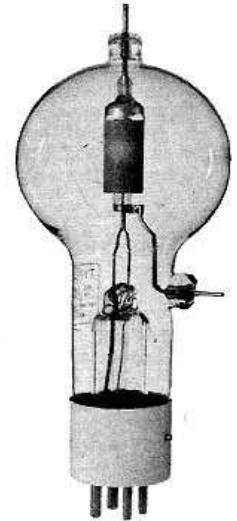

### RADIO FREQUENCY POWER AMPLIFIER AND OSCILLATOR

Class-C Telegraphy (Key-down conditions, 1 tube)

MAXIMUM RATINGS (Frequencies below 40 Mc.)	
D-C PLATE VOLTAGE	3000 MAX. VOLTS
D-C PLATE CURRENT	225 MAX. MA.
PLATE DISSIPATION	75 MAX. WATTS
GRID DISSIPATION	13 MAX. WATTS

TYPICAL OPERATION (Frequencies below 40 Mc.)

D-C Plate Voltage	1000	1500	2000	volts
D-C Plate Current	215	167	150	ma.
Plate Dissipation	75	75	75	watts
D-C Grid Voltage	-150	-250	-300	volts
D-C Grid Current	28	22	21	ma.
Peak R-F Grid Input Voltage (approx.)	320	355	425	volts
Driving Power, (approx.)	8	6	8	watts
Plate Power Input	215	250	300	watts
Plate Power Output	140	175	225	watts

### AUDIO FREQUENCY POWER AMPLIFIER AND MODULATOR

Class-AB<sub>1</sub> (Sinusoidal wave, two tubes unless otherwise specified)

MAXIMUM RATINGS	
D-C PLATE VOLTAGE	3000 MAX. VOLTS
MAX-SIGNAL D-C PLATE CURRENT, PER TUBE	225 MAX. MA.
PLATE DISSIPATION, PER TUBE	75 MAX. WATTS

<sup>1</sup> The effective grid-circuit resistance for each tube must not exceed 250,000 ohms.

(Effective 4-1-46) Copyright, 1946 by Eitel-McCullough, Inc.

### AUDIO FREQUENCY AMPLIFIER (Continued)

TYPICAL OPERATION

D-C Plate Voltage	1500	2000	volts
D-C Grid Voltage <sup>1</sup>	-105	-160	volts
Peak A-F Grid Input Voltage (per tube)	105	160	volts
Zero-Signal D-C Plate Current	67	50	ma.
Max-Signal D-C Plate Current	143	130	ma.
Driving Power	0	0	watt
Effective Load, Plate-to-Plate	10,200	21,200	ohms
Max-Signal Plate Power Output	64	110	watts
Max-Signal Plate Dissipation (per tube)	75	75	watts

### AUDIO FREQUENCY POWER AMPLIFIER AND MODULATOR

Class-B (Sinusoidal wave, two tubes unless otherwise specified)

MAXIMUM RATINGS

D-C PLATE VOLTAGE	3000 MAX. VOLTS
MAX-SIGNAL D-C PLATE CURRENT, PER TUBE	225 MAX. MA.
PLATE DISSIPATION, PER TUBE	75 MAX. WATTS
GRID DISSIPATION, PER TUBE	13 MAX. WATTS

TYPICAL OPERATION

D-C Plate Voltage	1000	1500	2000	volts
D-C Grid Voltage	-65	-105	-160	volts
Peak A-F Grid Input Voltage (per tube)	205	225	267	volts
Zero-Signal D-C Plate Current	100	67	50	ma.
Max-Signal D-C Plate Current	350	285	250	ma.
Max-Signal Avg. Driving Power (approx.)	7	6	5	watts
Max-Signal Peak Driving Power	26	23	19	watts
Effective Load, Plate-to-Plate	5,300	11,000	18,000	ohms
Max-Signal Plate Power Output	200	280	350	watts
Max-Signal Plate Dissipation (per tube)	75	75	75	watts

## APPLICATION

### MECHANICAL

**Mounting**—The 75TL must be mounted vertically, base up or base down. Flexible connecting straps should be provided between the grid and plate terminals and the external grid and plate circuits. The tube must be protected from severe vibration and shock.

**Cooling**—Provision should be made for ample circulation of air around the 75TL. In the event that the design of the equipment restricts natural circulation, a small fan or centrifugal blower should be used to provide additional cooling for the envelope and plate and grid seals.

### ELECTRICAL

**Filament Voltage**—The filament voltage, as measured directly at the filament pins, should be between 4.75 and 5.25 volts.

**Bias Voltage**—Although there is no maximum limit on the bias voltage which may be used on the 75TL, there is little advantage in using bias voltages in excess of those given under "Typical Operation," except in certain very specialized applications. Where bias is obtained by a grid leak, suitable protective means must be provided to prevent excessive plate dissipation in the event of loss of excitation.

**Plate Voltage**—The plate-supply voltage for the 75TL should not exceed 3000 volts. In most cases there is little advantage in using plate-supply voltages higher than those given under "Typical Operation" for the power output desired.

**Grid Dissipation**—The power dissipated by the grid of the 75TL must not exceed 13 watts. Grid dissipation may be calculated from the following expression:

$$P_g = e_{emp} I_c$$

where  $P_g$  = Grid dissipation,

$e_{emp}$  = Peak positive grid voltage, and

$I_c$  = D-c grid current.

$e_{emp}$  may be measured by means of a suitable peak voltmeter connected between filament and grid.<sup>2</sup> In equipment in which the plate loading varies widely, such as oscillators used for radio-frequency heating, care should be taken to make certain that the grid dissipation does not exceed the maximum rating under any condition of loading.

**Plate Dissipation**—Under normal operating conditions, the power dissipated by the plate of the 75TL should not be allowed to exceed 75 watts. Plate dissipation in excess of the maximum rating is permissible for short periods of time, such as during tuning procedures.

<sup>2</sup> For suitable peak v.t.v.m. circuits see, for instance, "Vacuum Tube Ratings," Eimac News, January, 1945. This article is available in reprint form on request.

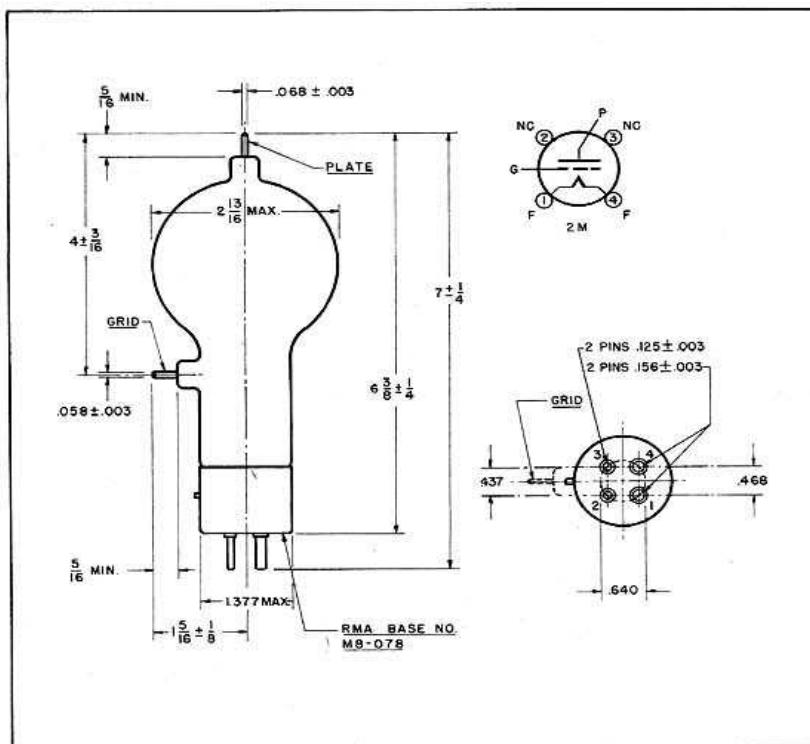

## DRIVING POWER vs. POWER OUTPUT

The three charts on this page show the relationship of plate efficiency, power output and grid driving power at plate voltages of 1000, 1500 and 2000 volts. These charts show combined grid and bias losses only. The driving power and power output figures do not include circuit losses. The plate dissipation in watts is indicated by  $P_p$ .

Points A, B, and C are identical to the typical Class C operating conditions shown on the first page under 1000, 1500, and 2000 volts respectively.

