



TECHNICAL DATA

8941/Y690

PLANAR TRIODE

The 8941 is a planar triode of ceramic/metal construction designed for use in airborne, ground and space applications as a grid or plate pulsed oscillator, amplifier, or frequency multiplier at frequencies up to 2.0 GHz. The extended grid to cathode insulator permits reliable operation in some applications to 12 KV¹. The other special features of this tube include high transconductance, high mu and high current capability from an arc-resistant, extended interface matrix cathode.

The tube is normally supplied without radiator and may be conduction, convection, heat sink or liquid cooled such as immersion in an insulating medium (eg. FC-75). Radiators for forced-air cooling as well as heat sink adapters permitting anode dissipations up to 750 watts are available as separate items.

The Y-690 is an 8941 which has been specially processed for series regulator and switch tube service and will operate in some applications to 15 KV¹. Solder tabs are available on special request permitting attachment of flying leads for grid, cathode and heater connections.



GENERAL CHARACTERISTICS¹

ELECTRICAL

Cathode: Oxide Coated, Unipotential

Heater: Voltage	6.3 ± 0.3 V
Current, at 6.3 volts	2.25 A
Transconductance (Average):	
I _b = 160 mA	75 mmhos
Amplification Factor (Average):	200
Direct Interelectrode Capacitance (grounded cathode) ²	
C _{in}	14.0 pF
C _{out}	0.11 pF
C _{gp}	2.5 pF
Cut-off Bias ³	-20 V max.
Frequency of Maximum Rating:	
CW	2000 MHz
Plate or Grid-Pulsed	2000 MHz

1. Characteristics and operating values are based upon performance tests and environmental conditions. These figures may change without notice as the result of additional data or product refinement. EIMAC Division of Varian should be consulted before using this information for final equipment design.

2. Capacitance values are for a cold tube as measured in a special shielded fixture. When the cathode is heated to the proper temperature, the grid-cathode capacitance will increase from the cold value by approximately 2 pF due to thermal expansion of the cathode.

3. Measured with one milliamper plate current and a plate voltage of 1 kVdc.

(Effective 10-15-75) © 1975 by Varian

Printed in U.S.A.



MECHANICAL

Maximum Overall Dimensions:

Length	2.235 in; 56.77 mm
Diameter	1.365 in; 34.60 mm
Net Weight	1.96 oz; 56 gm
Operating Position	Any
Maximum Operating Temperature:	
Ceramic/Metal Seals	250°C
Cooling	Conduction, convection, liquid or forced air

ENVIRONMENTAL

Shock: 11 ms, non-operating	60 G
Vibration: Operating, All Axis	10 G
Altitude; max., in suitably designed circuit	60,000 ft.

RANGE VALUES FOR EQUIPMENT DESIGN

	Min.	Max.
Heater: Current at 6.3 volts	2.05	2.50 A
Cathode Warmup Time	90	--- sec.
Interelectrode Capacitance ¹ (grounded cathode connection)		
C _{in}	12.5	16.5 pF
C _{out}	---	0.11 pF
C _{gp}	2.0	3.0 pF

1. Capacitance values for a cold tube as measured in a special shielded fixture. When the cathode is heated to the proper temperature, the grid-cathode capacitance will increase from the cold value by approximately 2 pF due to thermal expansion of the cathode.

GRID PULSED OR PLATE PULSED AMPLIFIER OR OSCILLATOR

ABSOLUTE MAXIMUM RATINGS:

DC PLATE VOLTAGE (grid pulsed) . .	10,000 VOLTS
PEAK PULSE PLATE VOLTAGE (plate pulsed)	12,000 VOLTS
DC GRID VOLTAGE	-350 VOLTS
INSTANTANEOUS PEAK GRID-CATHODE VOLTAGE	
Grid negative to cathode	-750 VOLTS
Grid positive to cathode	175 VOLTS
PULSE PLATE CURRENT	12 AMPERES
PULSE GRID CURRENT	3.0 AMPERES
AVERAGE PLATE DISSIPATION	
Forced Air Cooling ¹	750 WATTS
GRID DISSIPATION (Average)	2.0 WATTS
FREQUENCY	2.0 GHz
PULSE DURATION ²	6.0 μs
DUTY FACTOR ²0033

1. Using EIMAC radiator PN 158096.

Operating Conditions for 8941 in representative applications:

	Cathode Biased, rf Pulsed Amplifier ³	Grid Pulsed Amplifier
Frequency	1850	1090 MHz
Heater Voltage	6.3	6.3 V
DC Plate Voltage	4500	5000 Vdc
DC Grid Voltage	-40	-60 Vdc
Peak Video Plate Current	3.1	4.0 a
Peak Video Grid Current6	.75 a
Useful Power Output	4.2	10.0 kw (peak)
Pulse Duration	3.0	3.0 μs
Duty Cycle	0.04	0.001
Gain	11.5	12.0 dB
Bandwidth	20	--- MHz

2. For applications using longer pulse duration and/or higher duty cycle consult the nearest Varian Electron Tube & Device Field Office, or the Product Manager, EIMAC Division of Varian, Salt Lake City, Utah.

3. No gate pulse used.



PULSE MODULATOR AND PULSE AMPLIFIER SERVICE (Type Y-690)

ABSOLUTE MAXIMUM RATINGS:

DC PLATE VOLTAGE	15,000	VOLTS
PEAK PLATE VOLTAGE	18,000	VOLTS
DC GRID VOLTAGE	-350	VOLTS
INSTANTANEOUS PEAK GRID-CATHODE VOLTAGE		
Grid negative to cathode . .	-750	VOLTS
Grid positive to cathode . .	100	VOLTS
PULSE CATHODE CURRENT . .	16	AMPERES
DC PLATE CURRENT	600	MILLIAMPERES

AVERAGE PLATE DISSIPATION

Forced Air Cooling 1	750	WATTS
GRID DISSIPATION (Average)	2	WATTS
PULSE DURATION 2	6.0	μ S
DUTY FACTOR 20033	
CUT-OFF MU	90	

1. Using EIMAC radiator PN 158096.
2. For applications using longer pulse duration and/or higher duty cycle consult the nearest Varian Electron Tube & Device Field Office, or the Product Manager, EIMAC Division of Varian, Salt Lake City, Utah.

APPLICATION

For general application information please refer to the Planar Triode Operating Instruction Sheet. The operating instructions should be consulted prior to the designing of new requirements around the above tube type. For unusual and special applications consult the nearest Varian Electron Tube Field Office, or the Product Manager, EIMAC Division of Varian, Salt Lake City, Utah.

The cathode and grid flanges should not be altered in any way such as be machining or filing, since the final seal could be damaged. Maximum torque applied to flanges during installation should not exceed 15 inch pounds.

For optimum RF performance, the anode line should make good contact on the anode area indicated on the outline drawing.

Soldered connections may be made to the anode stud, grid or cathode flanges, and heater contacts where adequate heat sinking and good soldering practices are followed to minimize the heat applied to the tube and the thermal gradient across the metal to ceramic brazed areas. If forced air cooling is provided, auxiliary air flow, apart from the air flowing through the radiator, should be provided to cool the tube envelope and other tube terminals. Some conduction cooling is always provided through the contact terminals. However, these terminals usually exhibit poor heat transfer, often having a temperature gradient across them as high as 50°C.



8941/Y690

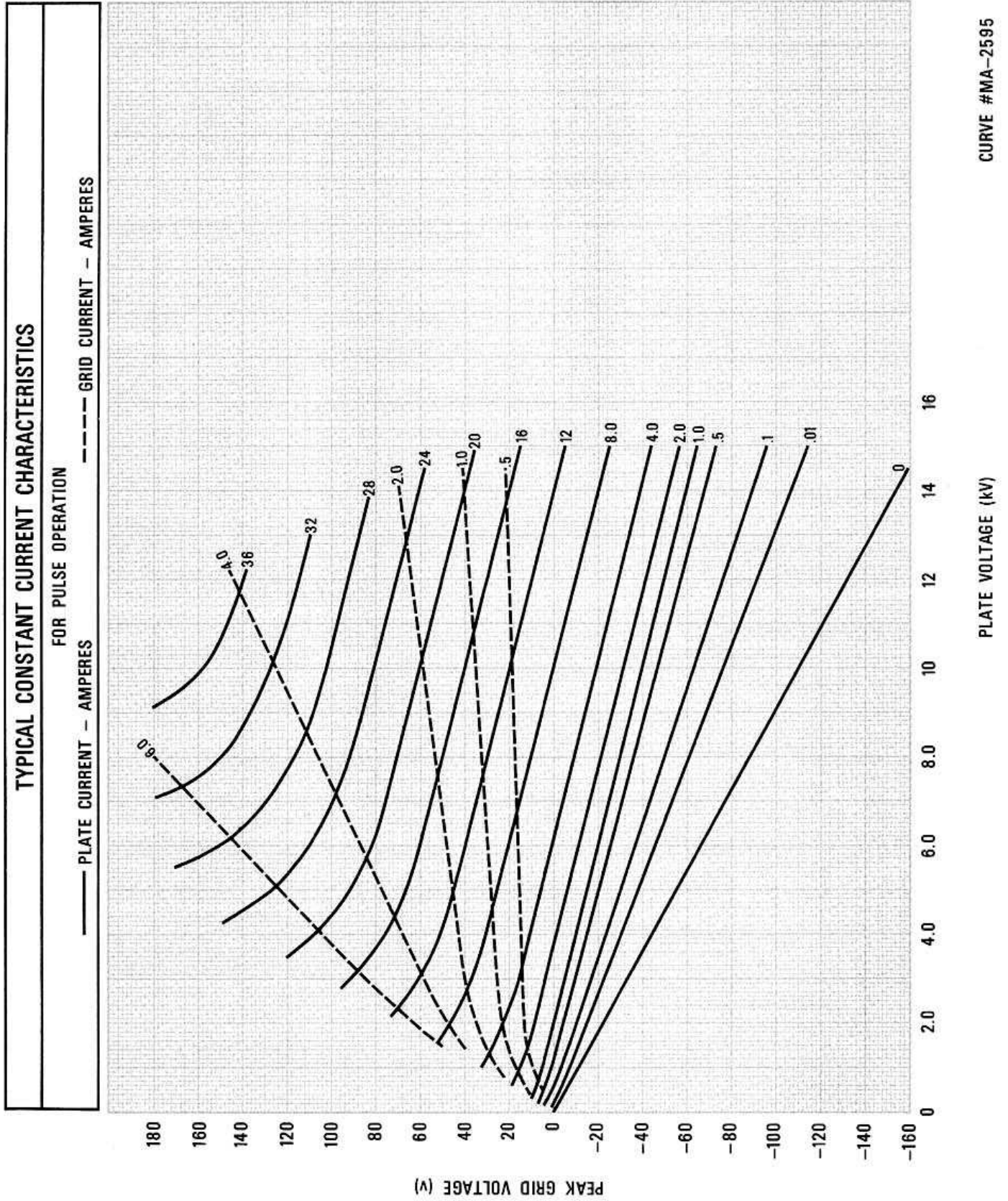

CURVE #MA-2595

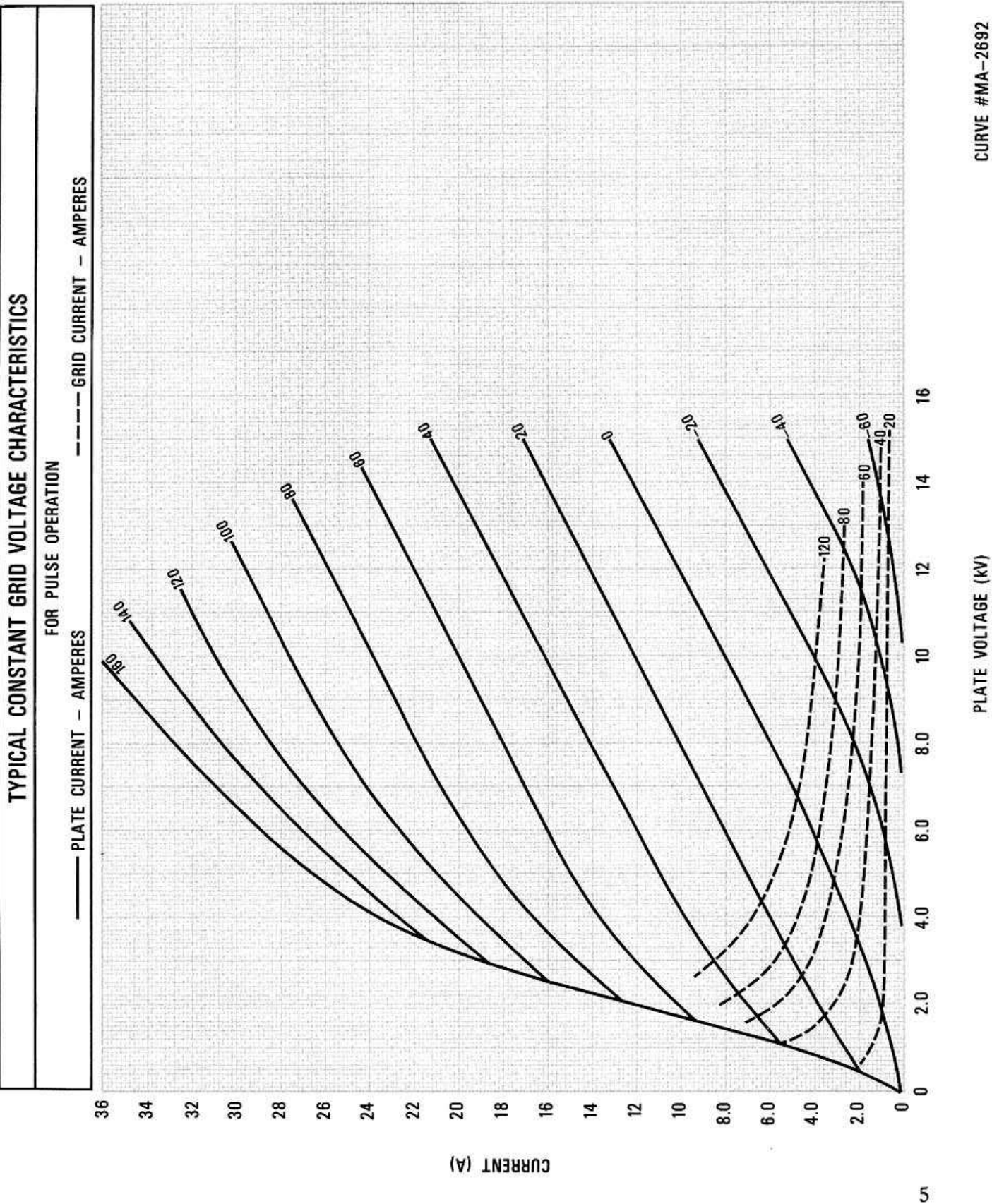



8941/Y690

TYPICAL CONSTANT PLATE CURRENT CHARACTERISTICS

NEGATIVE GRID VOLTAGE REGION

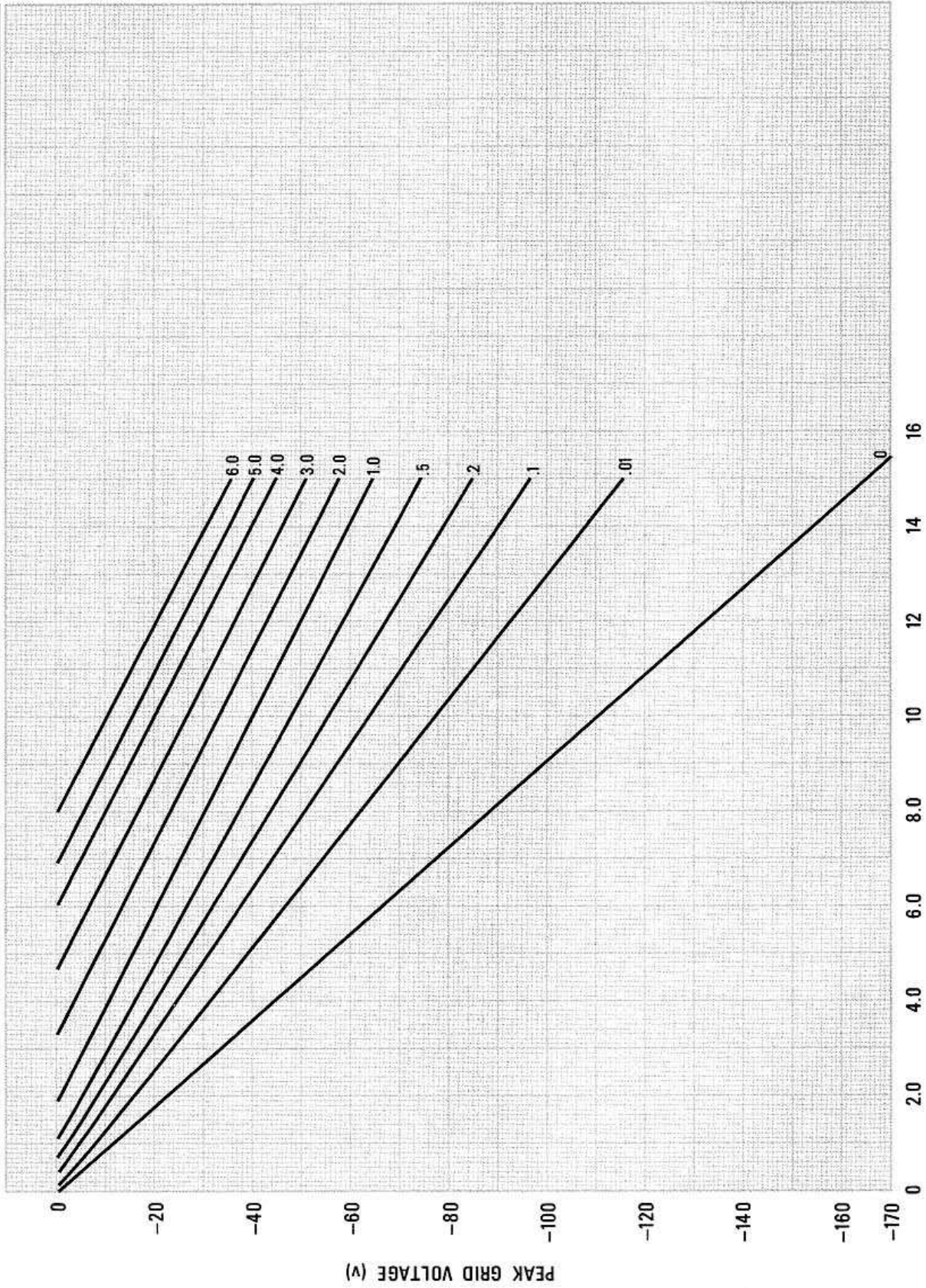

CURVE #MA-2691

PLATE VOLTAGE (kV)

PEAK GRID VOLTAGE (V)



AIR COOLING DATA FOR 8941

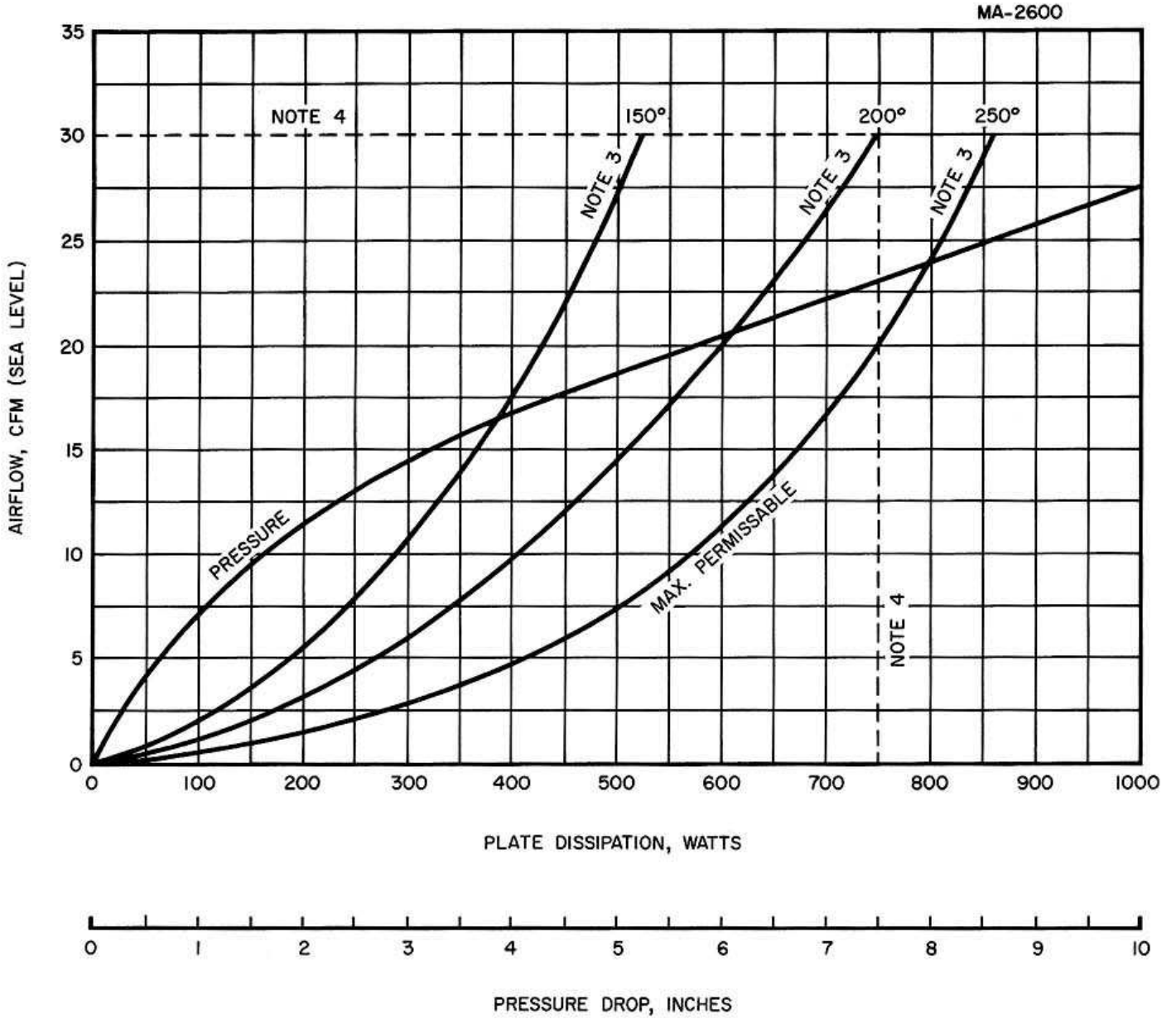

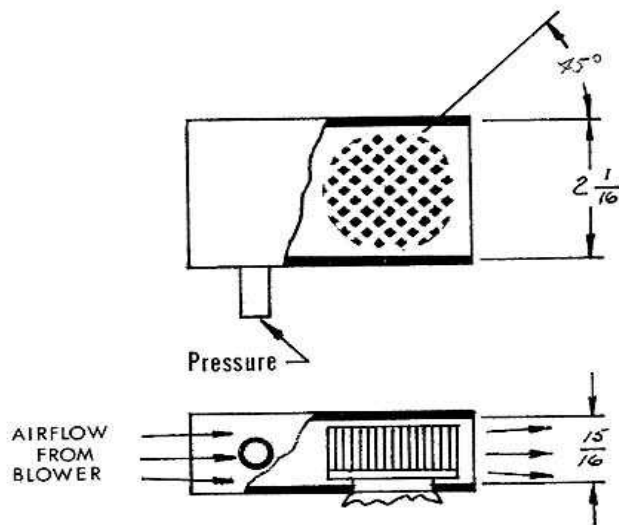

- COWLING DETAIL -

1. Inlet Air at 20°C
2. Use Radiator No. 158096 (Copper-Pin) in Cowling as shown.
3. Temp. measured at Anode Cup-Plate Insulator Seal.
4. Describes Typical MAX. CW Operating Point.



8941/Y690

COOLING DATA FOR 8941 IN FC 75 DIELECTRIC COOLANT

MA-2601

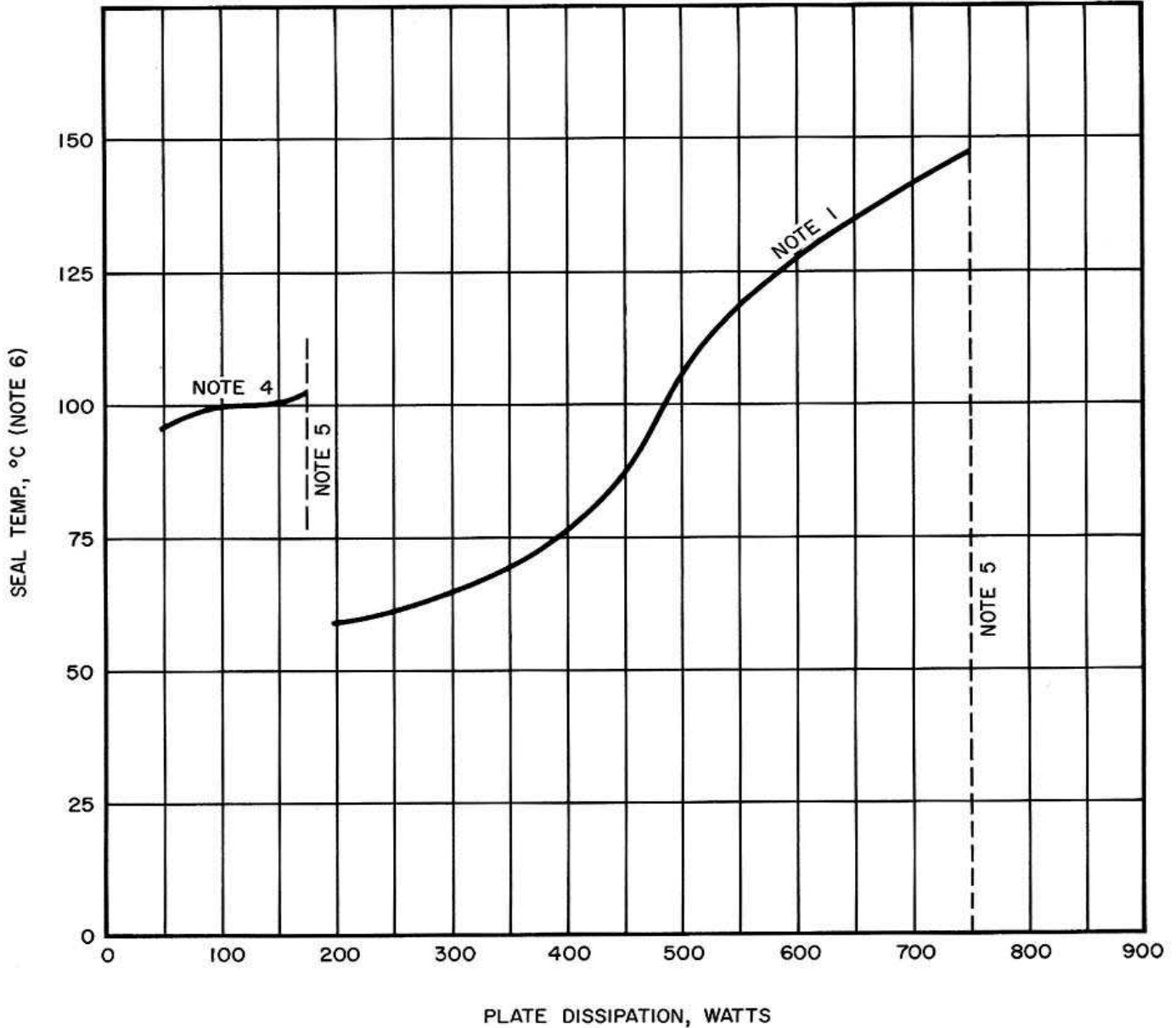

NOTES:

1. USE RADIATOR 158096 (Copper - Pin)
2. TUBE AXIS VERTICAL IN LIQUID.
3. LIQUID AMBIENT TEMPERATURE 40°C.
4. TUBE W/O COOLER STUD COOLING ONLY.
5. MAX. CW RATING - CONTACT PLANAR MGR. EIMAC, SLC ON INTERMEDIATE OR HIGHER POWERS THAN SHOWN.
6. SEAL TEMPERATURE IS MEASURED AT PLATE TO ANODE INSULATOR FLANGE (SEE 'V' ON OUTLINE DWG.)



8941/Y690

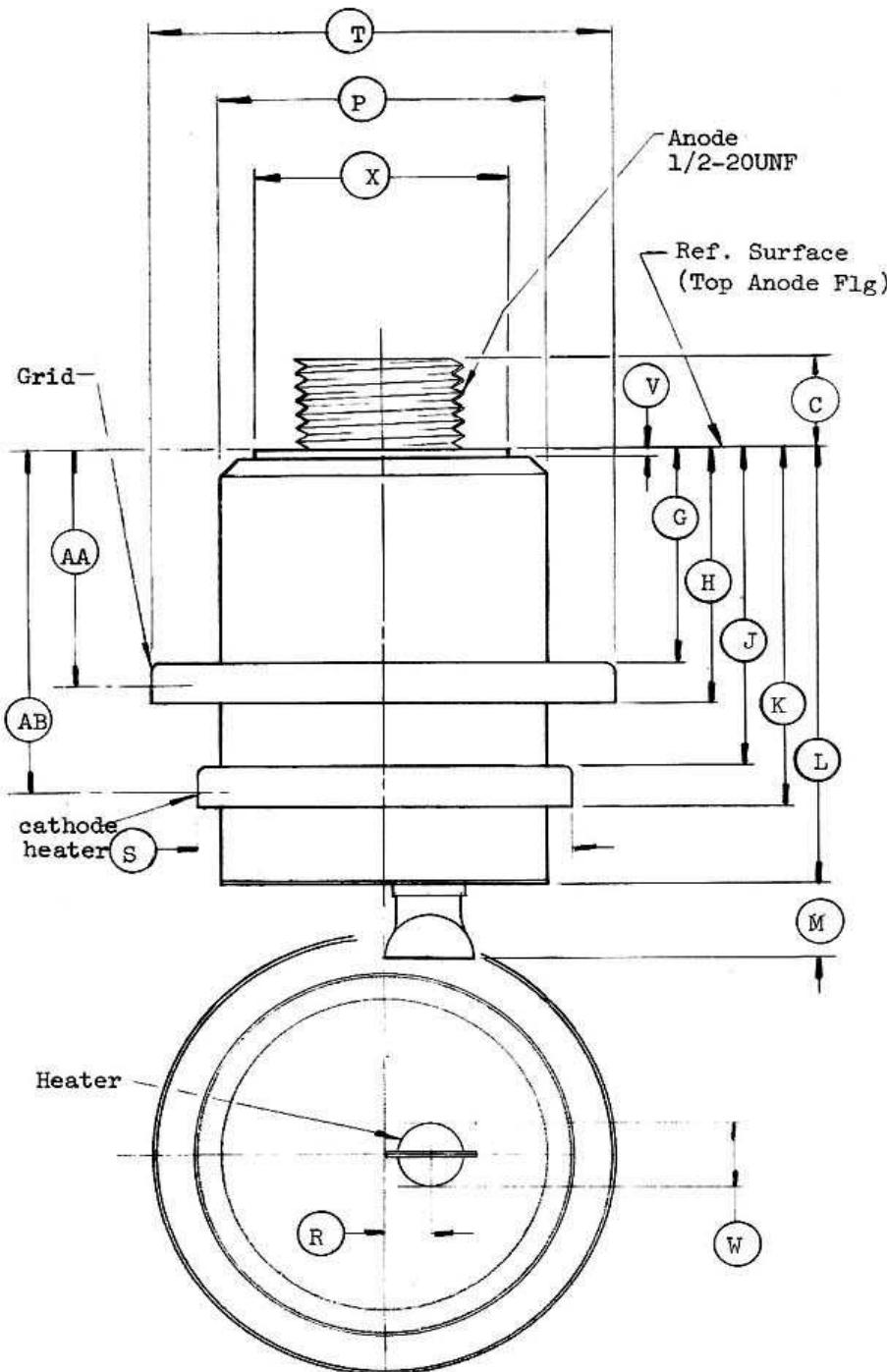

DIM	INCHES			MILLIMETERS		
	MIN	MAX	REF.	MIN	MAX	REF.
C	0.500	0.600	--	12.70	15.24	--
G	0.635	0.660	--	16.13	16.76	--
H	0.760	0.795	--	19.30	20.19	--
J	0.905	0.960	--	22.99	24.38	--
K	--	1.095	--	--	27.81	--
L	1.180	1.260	--	29.97	32.00	--
M	0.300	0.375	--	7.62	9.52	--
P	0.940	0.965	--	23.88	24.51	--
R	0.090	0.110	--	2.29	2.79	--
S	1.065	1.085	--	27.05	27.56	--
T	1.345	1.365	--	34.16	34.67	--
V	--	0.035	--	--	0.89	--
W	--	--	0.190	--	--	4.83
X	0.760	0.815	--	19.30	20.70	--
AA (see note 2,3)	--	--	0.710	--	--	18.03
AB (see note 2,3)	--	--	1.000	--	--	25.40

NOTES:

1. Ref. Dims .are for info only & are not req'd for inspection purposes.
2. Contact Surface Dims. AA & AB are for cavity design purposes only & are not intended as inspection criteria
3. Contact Surfaces are $\pm .030$ around dim. indicated.
4. TIR of Contact Surfaces are specified in individual Tube Electrical Specs.