



E I M A C
 Division of Varian
 SAN CARLOS
 CALIFORNIA

EM-102
 PULSED
 TRAVELING WAVE TUBE
 2.5-3.5 GHz
 1.5kW Peak

The EM102 is a grid modulated pulse TWT designed for use in airborne and missile environments. It delivers 1.5 kW peak saturation output power over the band 2.5-3.5 GHz. The EM102 is focussed by a periodic permanent magnet array and is compensated for operation at any temperature from -65°C to + 125°C and can be supplied either conduction or forced air cooled.

MAXIMUM RATINGS¹

Beam Voltage	8.0 kV
Cathode Current	1.8A
Grid Bias Voltage	-300V
Duty Cycle	2%
Pulse Duration	10 μs
Heater Voltage	6.8V
Heater Surge Current	5.0A
Source VSWR	2.0 : 1
Load VSWR	2.5 : 1

GENERAL CHARACTERISTICS

ELECTRICAL

Frequency Range	2.5-3.5 GHz
Peak output, (Min)	1.5 kW
Gain for 1.5 kW Output, (Min)	35 dB
Heater Voltage	6.8V
Heater Current, Typ	1.6A
Heater Warm-Up Time (Min).....	3.0 min
Grid Capacitance (To all other elements).....	40.0 pF
Grid Bias Voltage.....	-100V
Grid Drive Voltage ⁵	+250V

PHYSICAL

Dimensions	See Outline
Weight, Approx.	7.5 lb
Mounting Position	Any
RF Connectors	TNC

TYPICAL OPERATING CONDITIONS^{2,3}

Output	See Curves
Gain	See Curves
Beam Voltage.....	7.6 kV
Cathode Current, Peak.....	1.4A
Grid Bias Voltage	-100V
Grid Current, Peak.....	150 mA
Duty.....	2%
Pulse Duration.....	8 μs

RANGE VALUES FOR EQUIPMENT DESIGN^{2,4}

	<i>Min.</i>	<i>Max.</i>
Load VSWR.....		2.0 : 1
Beam Voltage	7.0	8.0 kV
Cathode Current Peak.....	1.2	1.8A
Grid Current.....	100	250 mA
Heater Voltage	6.8	6.8V
Heater Current.....	1.0	2.5A
Grid Voltage	-80	-300V

(See Footnotes on Page 2)

NOTE: These data may be used for prototype design purposes. Before establishing production design specifications, contact the nearest Varian Sales Office or Microwave Product Manager, EIMAC Division of Varian, 301 Industrial Way, San Carlos, Calif. 94070.



OUTPUT CHARACTERISTICS

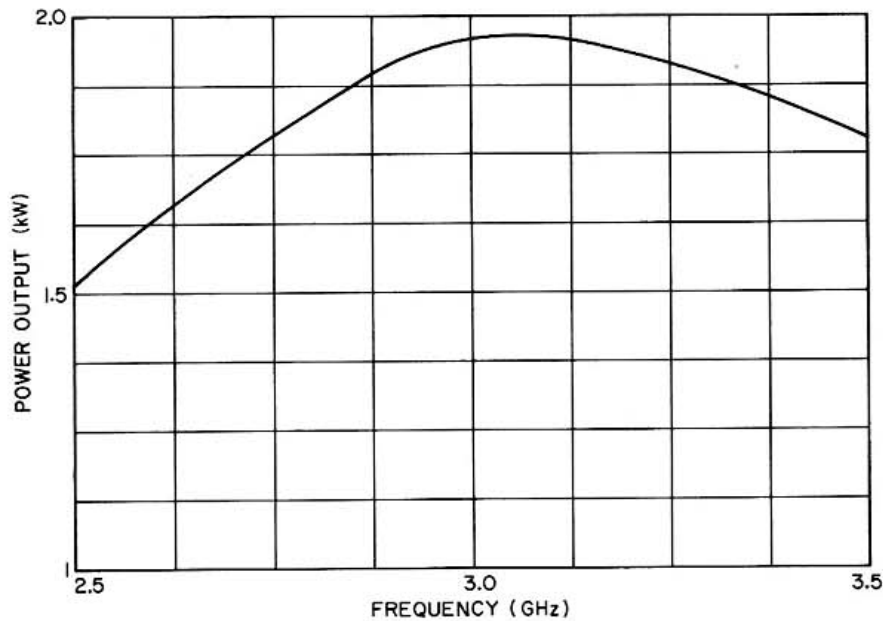

GAIN CHARACTERISTICS

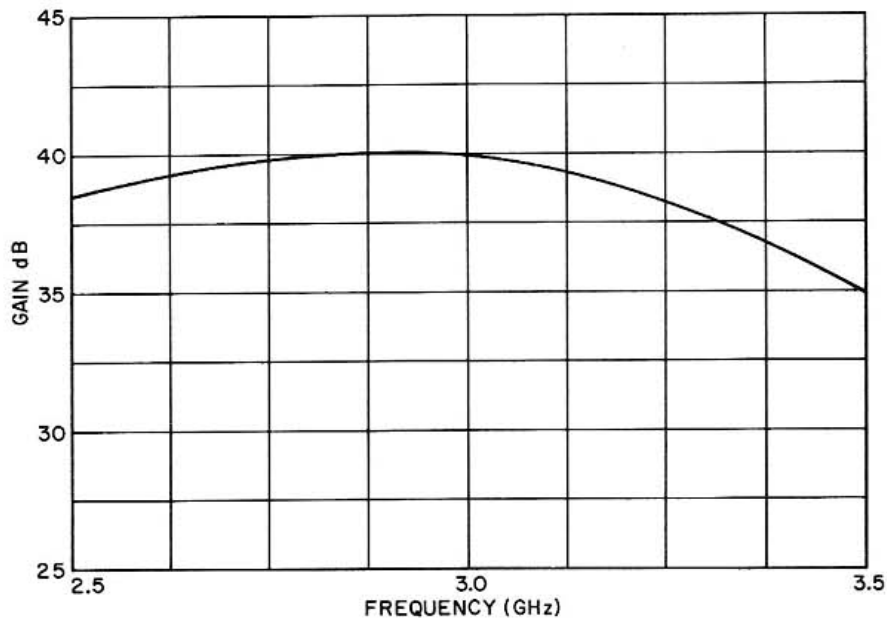

1. Ratings should not be exceeded under continuous or transient conditions. Simultaneous operation at more than one rating may not be possible. Equipment design should limit voltage and environmental variations so that no rating will ever be exceeded.
2. Characteristics and operating values are based on performance tests. These figures may change without notice with additional performance data or product refinement.
3. All voltages are referenced to the cathode. Gain and/or power output of the tube may be optimized at a slightly different voltage(s) depending on operating frequency.
4. These values are acceptance limits for the range of operating voltages that will optimize output power, gain, or bandwidth over the frequency range.
5. Voltage reference: grid to cathode.

CONVECTION COOLED

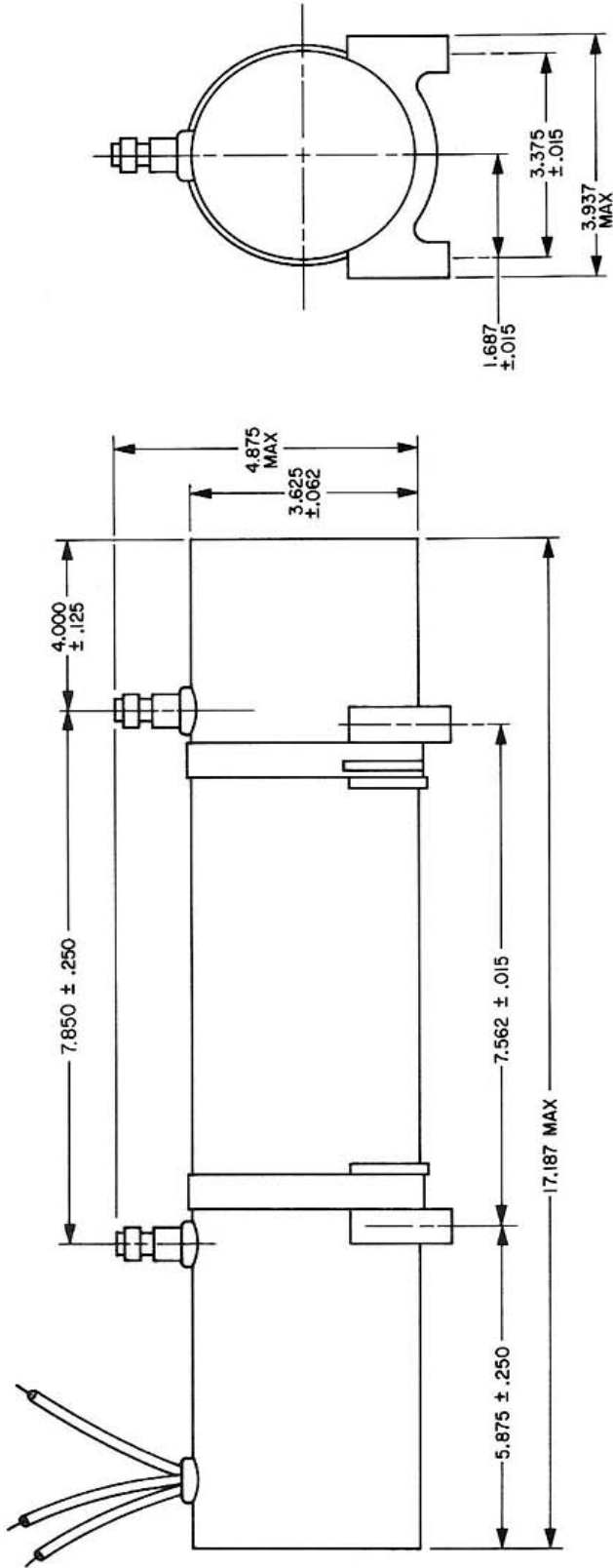

LEAD	ELEMENT
GREEN	GRID
BROWN	HEATER
YELLOW	HEATER/CATHODE



CONDUCTION COOLED

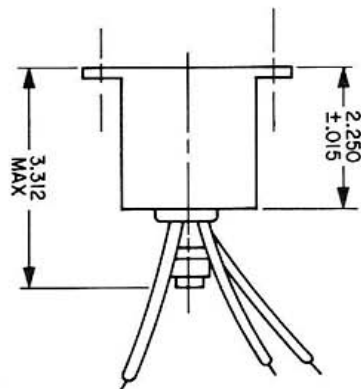
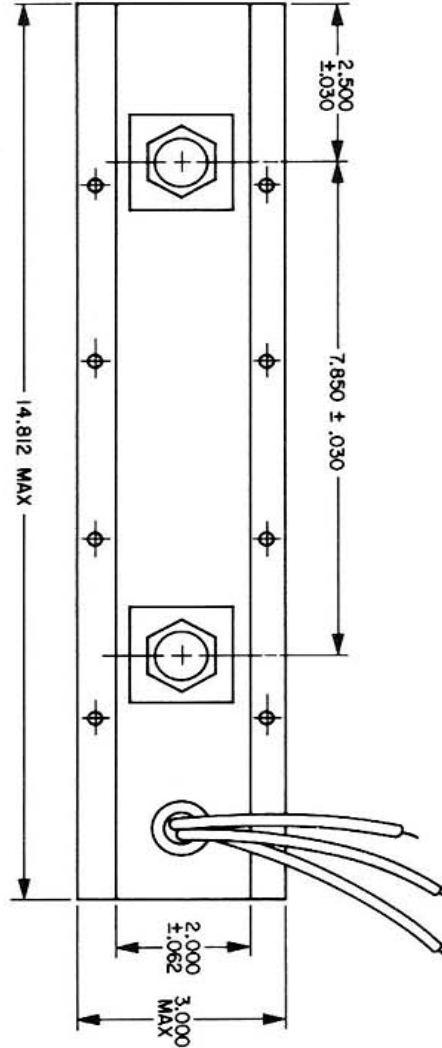

LEAD	ELEMENT
GREEN	GRID
BROWN	HEATER
YELLOW	HEATER/CATHODE