**APPLICATION**

The ML-7003A is a ruggedized shielded-grid triode capable of withstanding severe conditions of shock and vibration, while still delivering a peak pulse power output of 2.5 megawatts in switch tube service. The tube is rated for 90 amperes peak pulse cathode current and can hold off 45 kVdc plate voltage.

CONSTRUCTION

The ML-7003A employs a beamed electrode structure to minimize driving power, utilizing the same active-area dimensions as found in the ML-7003. This design avoids the fine-wire grids usually used in tetrodes and provides a rugged structure. The shield grid is strapped to the cathode internally and protects the cathode from transient arcs. These features provide a tube which operates much more stably at high voltages than hard-tube modulators of earlier design. The high amplification factor coupled with low grid current results in unusually low driving power requirements. Additionally, the input and output circuits are isolated so that feedback capacitance is small. The cathode is a unipotential oxide-coated type. When cooled by forced air, the anode is capable of dissipating 3 kW with 200 cfm air flow.

The internal structure of the ML-7003A has been extensively reinforced and shock absorbers have been provided as an integral part of the anode radiator. The tube can withstand vibration testing from 5 to 1000 Hz (5g acceleration, 58-1000 Hz) and will tolerate shock pulses of 15g in operating (30g in non-operating) conditions without any indication of electrode shorting.

WARNING

When operating at peak voltage in excess of 15 kV, this electron tube may give off x-rays which can be harmful unless adequately shielded by the enclosure within which the tube is used. Instructions for protective installation are given in National Bureau of Standards Handbook 114, "Safety Standard for Non-Medical X-Ray and Sealed Gamma Ray Sources." Additional information is available in National Council on Radiation Protection and Measurements Report No. 33, "Medical X-Ray and Gamma Ray Protection for Energies up to 10 MeV." Periodic checks of shielding effectiveness are also required since x-ray radiation levels may increase with the operating life of the tube.

ORDERING NOTES

Refer to Machlett price list. When ordering specify:

- tube type
- accessories
 - heater connector (small)
F-21989
 - cathode/heater connector (large)
F-21991
 - grid connector
F-21987

SPECIFICATIONS**ELECTRICAL CHARACTERISTICS**

Heater Voltage:	6.0 (+ 10%, - 5%) V**
Heater Current:	60 A
Heater Starting Current, maximum:	300 a
Cathode Warm-up Time:	15 minutes*
Amplification Factor:	200
Interelectrode Capacitances:	
Grid Plate:	1.6 pF
Input (Grid-Cathode):	230 pF
Output (Plate-Cathode):	25 pF

MECHANICAL CHARACTERISTICS

Mounting Position (support tube by anode radiator only):	Any
--	-----

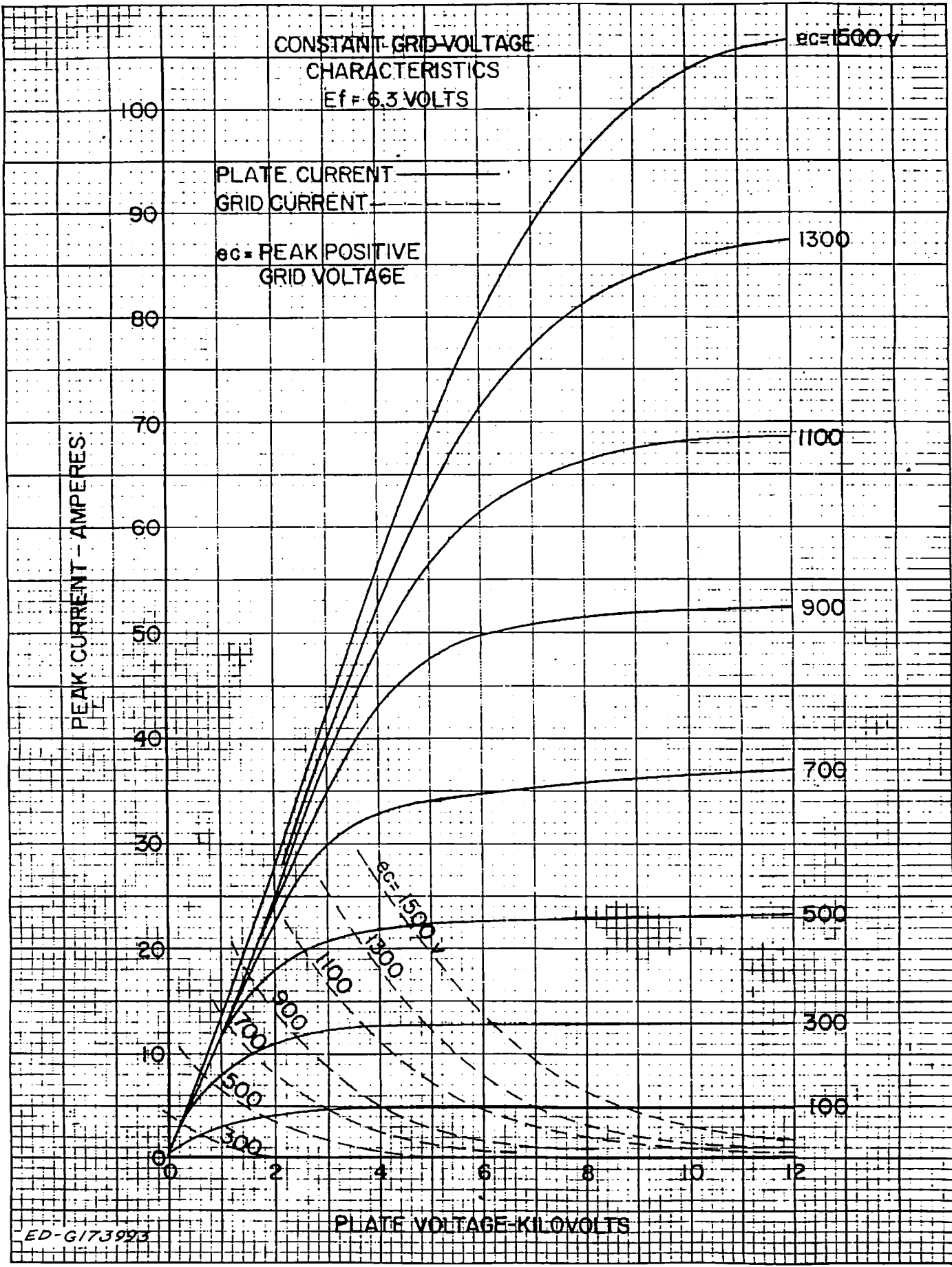

Forced-Air Cooling†

Air Flow on Anode,
 Minimum for
 3kW Dissipation: 200 cfm at 0.3" water
 Air Flow on Grid: 25 cfm
 Maximum Incoming Air
 Temperature: 75 °C (167 °F)

Maximum Glass
 Temperature: 175 °C (347 °F)†

Net Weight, approximate: 27 lbs. (12 kg)

*For accelerated cathode warmup, the heater may be energized at 7.5 volts for 5 minutes and then reduced to rated value for high voltage operation.

†Sufficient coolant flow must be provided to maintain glass temperatures at less than 175 °C (347 °F) under all conditions of operation.

**6.3 volts nominal heater voltage is recommended for new-design applications.

**MAXIMUM RATINGS
 AND TYPICAL OPERATING CONDITIONS**

Pulse Modulator or Pulse Amplifier

Maximum Ratings, Absolute Values*	ML-7003A	
DC Plate Voltage	45 kv	
Peak Plate Voltage	50 kv	
DC Grid Voltage	- 600 volts	
Peak Positive Grid Voltage	+ 1.5 kv	
Peak Negative Grid Voltage	- 1500 volts	
Pulse Cathode Current	90 a †	
DC Plate Current	600 mA	
Grid Dissipation	25 W	
Plate Dissipation	3.0 kW	
Pulse Duration*	10 μsec ‡	
Duty Factor*	0.03 ‡	

Typical Operation	ML-7003A	
DC Plate Voltage	35 kv	40 kv
DC Grid Voltage	- 300 volts	- 350 volts
Pulse Positive Grid Voltage	+ 0.8 kv	+ 1.3 kv
Pulse Plate Current	40 a	80 a
Pulse Grid Current	3 a	4 a
Pulse Driving Power	3.3 kw	6.6 kw
Pulse Power Output	1.2 Mw	2.5 Mw
Plate Output Voltage	30 kv	32 kv
Duty Factor006	.003

*All given maximum ratings may not apply simultaneously. Due to the possibility of instantaneous overheating of electrodes during the pulse, it may be necessary to restrict some of the parameters, e.g., peak plate current, tube drop, pulse duration, duty or average dissipation, in order not to adversely affect the performance of the tube. Because of the many possible combinations of operating conditions, all restrictions cannot be delineated here, and it is suggested to review new applications with the Machlett Engineering Department.

†For pulse cathode currents above 60 amperes, minimum heater voltage for the ML-7003A is 6.3 volts.

‡For applications requiring longer pulse duration or higher duty factors, consult the Machlett Engineering Department.

TUBE PROTECTION

If shock and vibration protection is required, the ML-7003A should be installed in a tube support as shown. The tube should be supported by the shock rings only. Provisions must be made for the anode air cooler fins to clear the tube support. The inside diameters of the tube support and the clamp ring must be as shown.

Dimension "A" must be such that total compression of the rubber cushions will be between .100" and .160". To secure this compression it might be necessary to provide shims under the clamping ring to compensate for variations from tube to tube in the dimensions of the anode air cooler.

The anode connection should be made to the clamp ring. This ring makes contact with the upper shock ring, which is connected to the anode air cooler by flexible wires located under the shock ring.

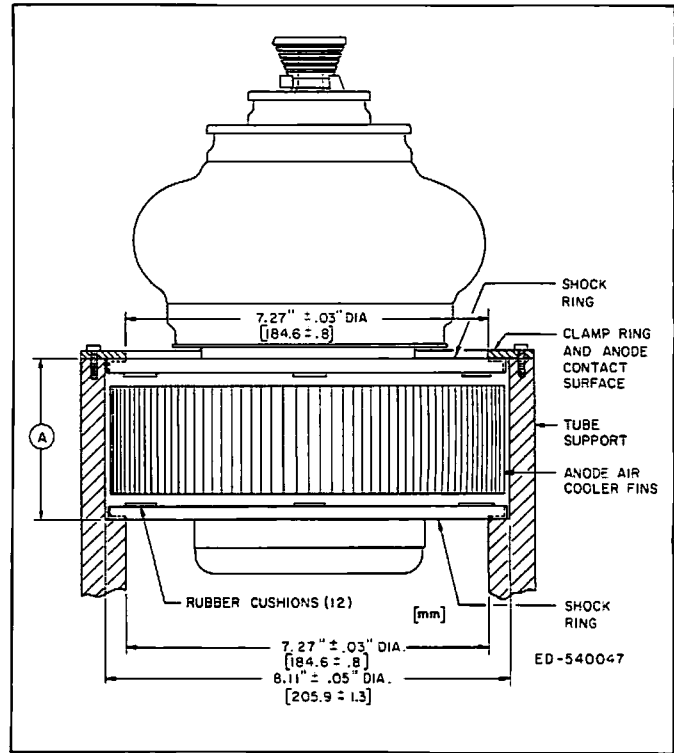

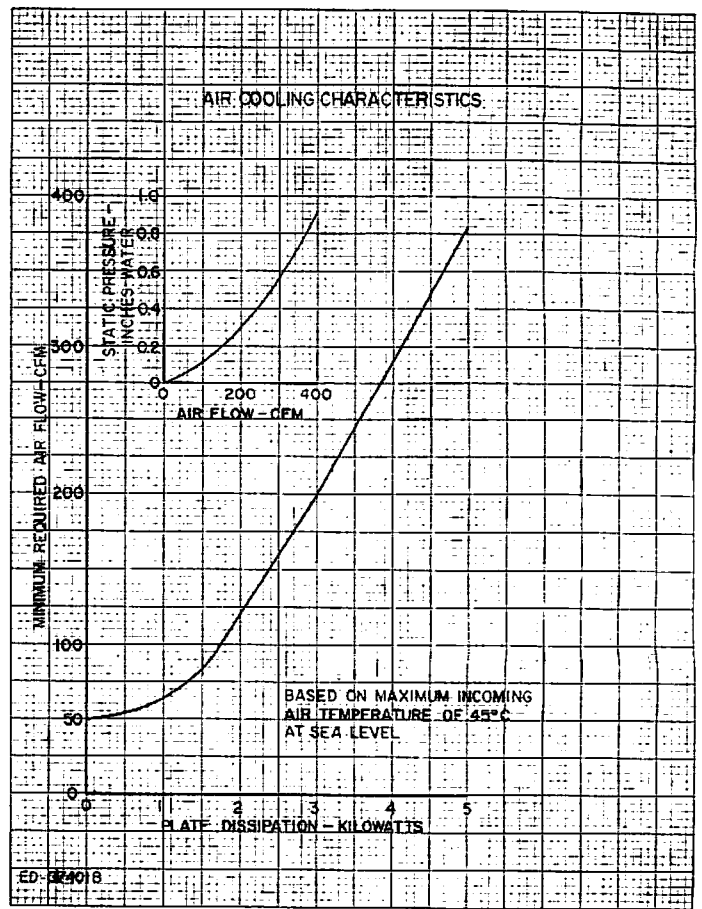
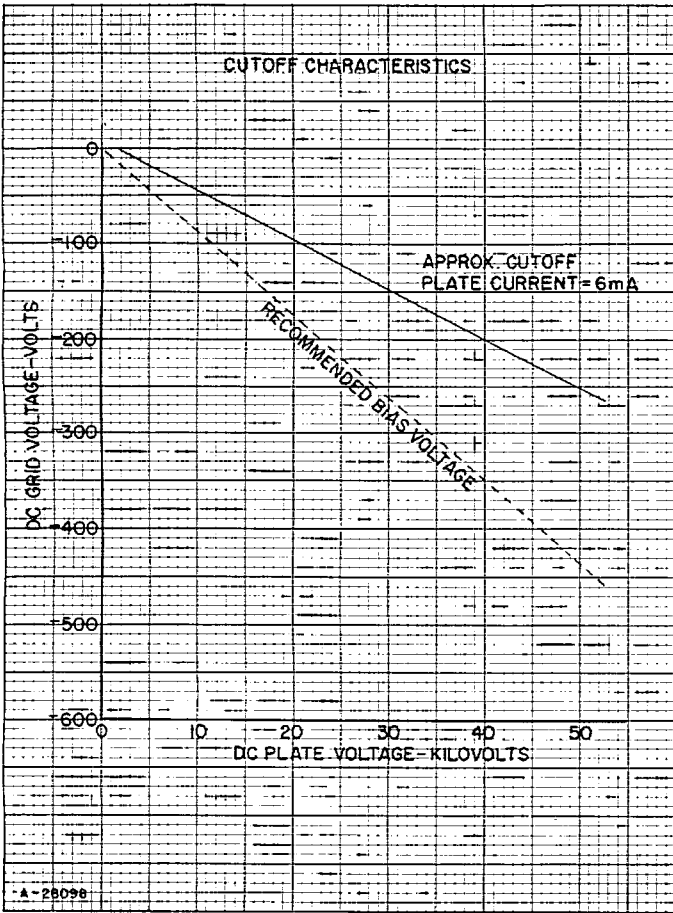

OUTLINE DATA

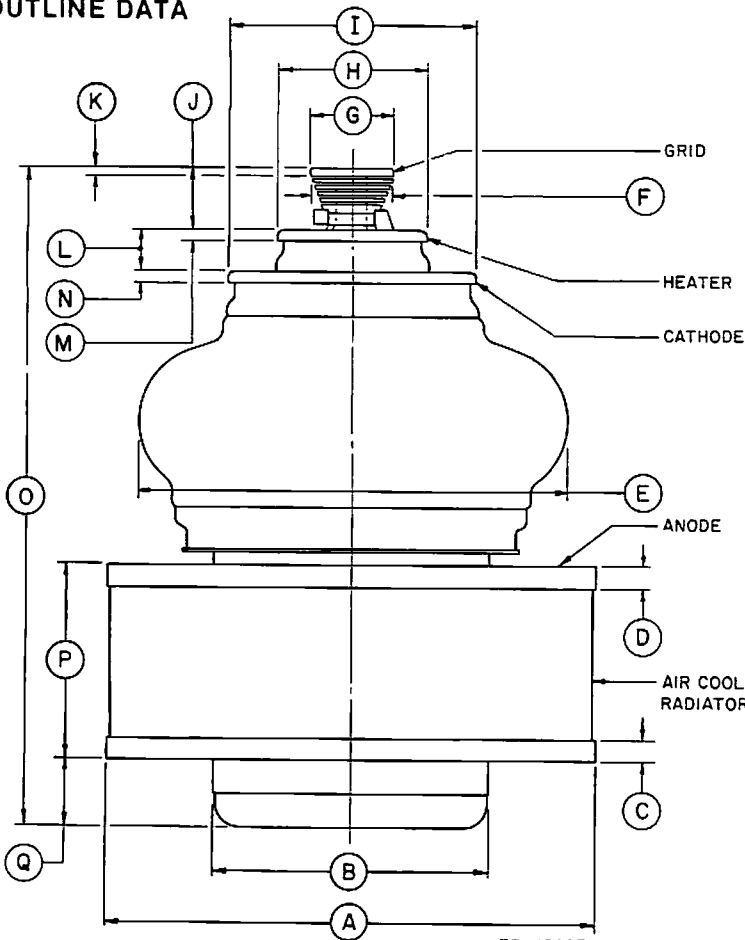

DIMENSIONS FOR OUTLINE OF ML-7003A

Ref.	(Inches)	(mm)		
	Orig. Dim.	Minimum	Nominal	Maximum
A	8.000 ± .050	201.9	203.2	204.5
B	4.5 ± .062	112	114	116
C	.36 ± .06	7.5	9.1	10.7
D	.36 ± .06	7.5	9.1	10.7
E	7.125	—	—	181
F	1.312 + 0 - .016	32.9	33.3	33.3
G	1.375 ± .005	34.80	34.93	35.06
H	2.438 ± .016	61.51	61.91	62.31
I	4.062 ± .016	102.8	103.2	103.6
J	1.031 ± .062	24.6	26.2	27.8
K	.141 ± .016	3.1	3.6	4.1
L	.688 ± .031	16.6	17.5	18.4
M	.188 ± .016	4.3	4.8	5.3
N	.188 ± .016	4.3	4.8	5.3
O	11.125 ± .25	276	283	290
P	3.25 ± .062	81.0	82.6	84.2
Q	1.125 ± .062	27.0	28.6	30.2