



TECHNICAL DATA

SK-630 SK-630A AIR-SYSTEM SOCKET

The EIMAC SK-630 is one of the Air-System Sockets recommended for use with those tubes listed on the back of this data sheet or other tube types having the same special nine-pin base. A ceramic SK-626 Air Chimney or a fiberglass-reinforced silicone resin SK-636 Air Chimney are also available and are recommended for use with the socket when air-cooled tubes are to be employed.

When this socket is used, connection is made to each of the tube electrodes except the anode, and to one side of the integral screen-grid by-pass capacitor. The SK-630 Air-System Socket is humidity and salt-spray resistant. The SK-630A is an improved SK-630 which includes a slightly modified screen by-pass capacitor sealed with an improved encapsulating material to insure reliable performance under high humidity or moisture conditions.

BASE CONNECTIONS

The SK-630 Air-System Socket consists of eight screen-grid contact fingers, seven pin contacting terminals (no contact is made to pin No. 5), a center control-grid terminal, and an integral screen by-pass capacitor. The cathode of the tube is connected to its external circuits by the four even-numbered base pins which are connected in parallel to minimize the effects of lead inductance. These terminal lugs are connected directly to the metal shell of the socket and will automatically be grounded when the socket is mounted to a metal chassis.

SCREEN-GRID BY-PASS CAPACITOR

Incorporated in the socket structure is a low-inductance screen by-pass capacitor, 1100 pF $\pm 20\%$, which provides a short radio-frequency path to ground. The silvered-mica dielectric, encapsulated in epoxy resin, is humidity and salt-spray resistant. The sockets are hi-voltage breakdown tested at 2000 volts dc and are rated for use at 1000 volts dc.

When this socket is mounted on a grounded chassis, one side of the screen-grid by-pass capacitor will automatically be grounded.

MATERIALS AND FINISHES

The metal shell, or body, of the socket is silver-plated brass. The screen-grid contact fingers and base pin terminals are fabricated of beryllium-copper, heat-treated after forming, then silver-plated. The center control-grid terminal is silver-plated brass as are the toe clamps which are supplied for mounting purposes.

The socket insulating material, polytrifluorochloroethylene, is chemically inert, non-flammable, will not absorb water or water vapors, and is not affected by acids or alkalies. It will not react to normal solvents, except in the case of halogenated compounds which will induce minor dimensional changes. Its physical characteristics are stable over a temperature range of -196°C to $+199^{\circ}\text{C}$ and it is resistant to embrittlement and thermal shock.

NET WEIGHT (Approximate) 4 Oz.; 114 gms

INSTALLATION

The SK-630 and SK-630A Air-System Socket can be mounted on chassis decks or partitions or in coaxial tuning devices with no modification to the socket. Chassis mounting is accomplished by cutting a 2-1/4" diameter hole in the chassis deck or partition. The socket is then placed in the hole and held securely by the three toe clamps provided.

If the socket is to be used in a coaxial line, it may be mounted directly on the end of the input line outer conductor. The socket skirt fits snugly on a 1-5/8" diameter cylinder and four screw holes are provided for fastening as shown in the outline drawing.

(Cont'd)

(Revised 7-1-75) © 1961, 1967, 1975 by Varian

Printed in U.S.A.



TUBE EXTRACTOR

The SK-604 is a spring-steel device useful for inserting and extracting tubes of the type used in the SK-630 Air-System Socket. It is recommended for use where the construction of the equipment makes it difficult or impossible to grasp the tube by hand or when it is necessary to handle the tubes while they are still hot from recent use.

THE SK-630 AND SK-630A AIR-SYSTEM SOCKETS ARE RECOMMENDED FOR USE WITH THE FOLLOWING TUBES:

7034/4X150A
7203/4CX250B
7580W/4CX250R
7609

8249/4W300B
8321/4CX350A
8322/4CX350F
8621/4CX250FG

8904/4CX350FJ
8930
8957/4CX250BC

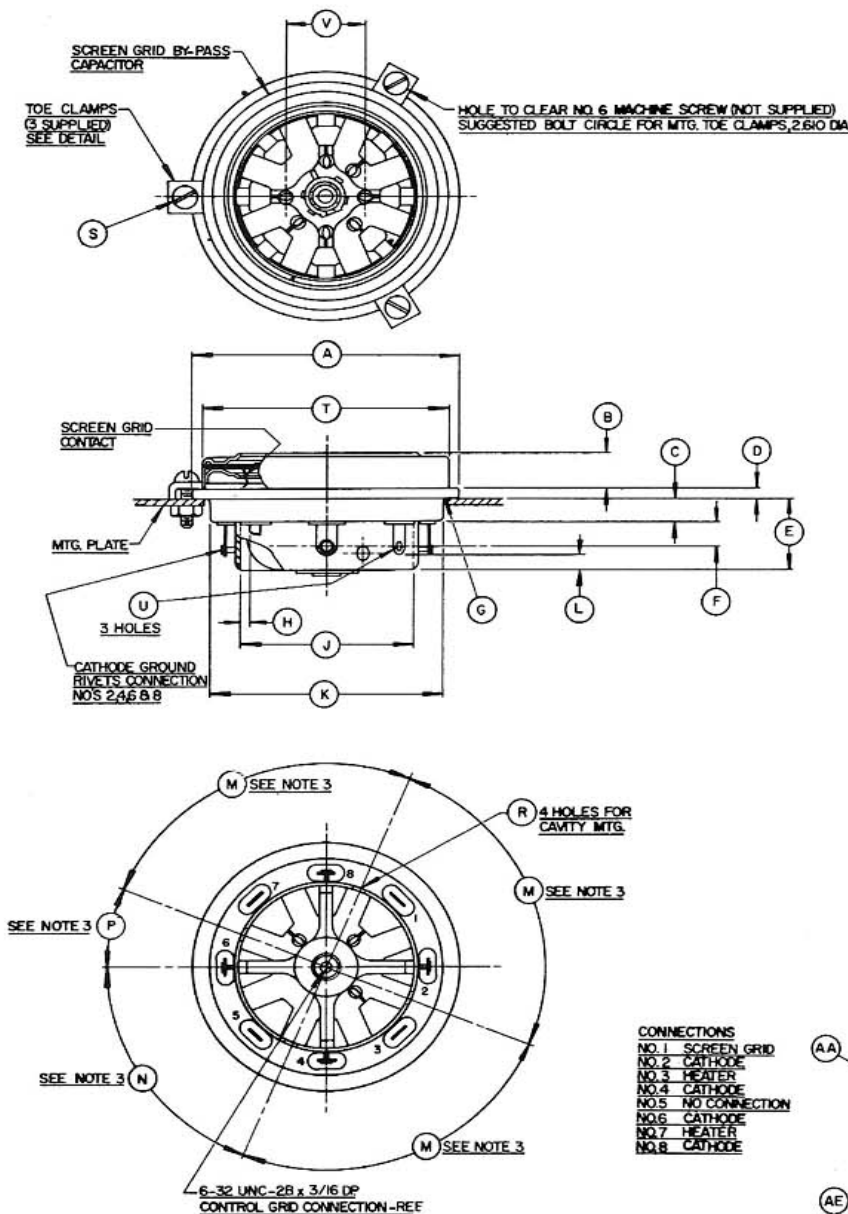

DIM	INCHES			MILLIMETERS		
	MIN.	MAX.	REF.	MIN.	MAX.	REF.
A	2.438	2.478	--	61.92	62.94	--
B	0.348	0.378	--	8.84	9.60	--
C	0.203	0.235	--	5.16	5.97	--
D	0.105	0.145	--	2.67	3.68	--
E	0.700	0.740	--	17.78	18.80	--
F	--	--	0.250	--	--	6.35
G	--	0.031R	--	--	0.79R	--
H	--	--	0.078	--	--	1.98
J	1.633	1.643	--	41.48	41.73	--
K	2.188	2.208	--	55.57	56.08	--
L	0.172	0.204	--	4.37	5.18	--
M	89°	91°	--	89°	91°	--
N	66.5°	68.5°	--	66.5°	68.5°	--
P	21.5°	23.5°	--	21.5°	23.5°	--
R	--	--	0.144*	--	--	3.66*
S	0.142*	--	--	3.61*	--	--
T	2.285	2.305	--	58.04	58.55	--
U	--	--	0.090*	--	--	2.29*
V	--	--	0.687	--	--	17.45
AA	1.230R	1.270R	--	31.24	32.26	--
AB	0.292	0.332	--	7.42	8.43	--
AC	0.142*	0.146*	--	3.61*	3.71*	--
AD	0.136	0.176	--	3.45	4.47	--
AE	0.105	0.145	--	2.67	3.68	--
AF	--	0.062R	--	--	1.57R	--
AG	0.261	0.301	--	6.63	7.64	--

* DIAMETER

- NOTES:
- REF DIMS ARE FOR INFO ONLY AND ARE NOT REQD FOR INSPECTION PURPOSES.
 - CAPACITANCE, 100 MMFD ± 20% VOLTAGE, 2000VDC TEST, 1000 WVDC.
 - TOLERANCES ARE NOT CUMULATIVE.
 - WORD EMAC IN SOCKET IDENTIFICATION LABEL IS LOCATED (APPROX) NEXT TO PIN 5.
 - GROUND CATHODE

CONNECTIONS
NO. 1 SCREEN GRID
NO. 2 CATHODE
NO. 3 HEATER
NO. 4 CATHODE
NO. 5 NO CONNECTION
NO. 6 CATHODE
NO. 7 HEATER
NO. 8 CATHODE

