

# INFORMATION BULLETIN

JUNE, 1937

NO. 11

## WESTINGHOUSE NEW HIGH FREQUENCY TUBE WL-461

### U S E S

Greater power output at the shorter wavelengths has always been the watchword of the numerous fields of application in which oscillator and amplifier tubes have been so usefully applied.

A new and significant development in this direction is the Westinghouse WL-461 short wave tube which represents a decided advance in electronic tube design.

The WL-461 tube, because of its radically different construction, is superior to the conventional power tubes now used for radio, therapy and other high frequency purposes. In addition to the high output which may be obtained at 6 meters, the unique construction makes it possible to obtain much greater output in radio therapy sets at wavelengths below 6 meters than was the case with the earlier and more conventional types of tubes.

This new tube can also be readily used in ultra high frequency circuits wherever a three element radio-frequency amplifier tube of its characteristics is required. The several improvements incorporated in its construction also make it possible to conduct experimental work in the ultra high frequency field with greater power output than was heretofore conveniently available.

This tube is of special interest to every one designing and using high frequency circuits and tubes as it has been engineered to utilize the recent advances discovered during the extensive developments which have been carried out in connection with electronic tube work. The usual types of bases, stems, presses and lead wires have been supplanted in this distinctly modern power tube by supporting

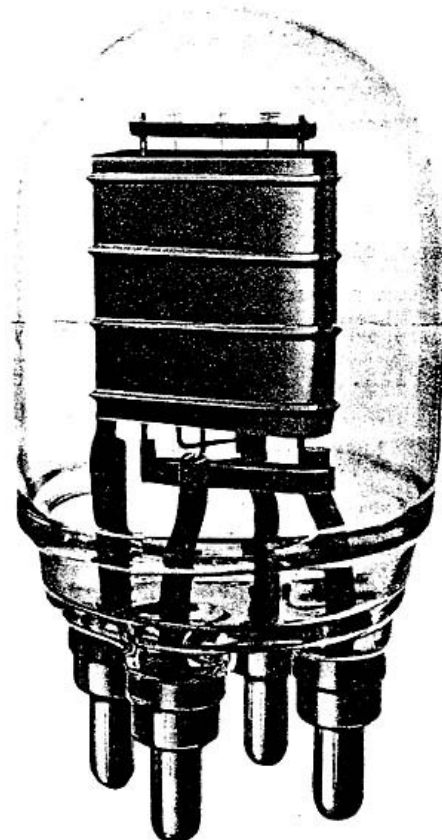

WL-461 HIGH FREQUENCY OSCILLATOR  
AND AMPLIFIER

the grid, filament and plate electrodes by short heavy rods terminating in rugged metal thimbles which make direct connection to the external circuit. Mounting thimbles of this type have been used for several years on high wattage airport flood lamps where their heavy current carrying ability has been satisfactorily demonstrated.

## D E S C R I P T I O N

The high conductivity of the large support rods results in low impedance paths inside of the tube. By clamping the external circuit directly to the metal thimbles a very low impedance path is also provided between the output tank circuit and the tube electrodes. This feature, together with the low inter-electrode capacity and high mutual conductance gives optimum output at 50 megacycles and large useful output at frequencies as high as 100 megacycles. Other features which make the tube particularly useful for any kind of high frequency service are: the short electron transit time resulting from the rather close spacing between the filament, grid, and plate electrodes, and the use of tantalum as an anode material, as well as a convenient arrangement of the mounting thimbles. The simplification of the internal supporting structure has also resulted in an economical size so that only a minimum amount of space need be reserved for the tube.

As indicated above, the special arrangement of the mounting thimbles makes it convenient to utilize improvements in the circuit so that parasitic and other troublesome effects may be greatly reduced. The most effective way to use the tube is to mount it directly in the circuit by clamping the thimbles directly to the leads.

In most ultra high frequency or short wave applications it is advisable to use two tubes in a push pull or similar circuit. The most convenient way to use the tubes in this type of circuit is to place them end to end with the thimbles spaced approximately one inch apart. This results in the shortest possible leads and also gives considerable economy in the space required.

The inter-electrode capacitance of a high frequency tube should be kept to as low a figure as possible. A convenient way to accomplish this is by using wide spacing of the elements; namely, by using a plate of rather wide dimensions so that the spacing between the filament, grid, and plate, are as large as possible. However, investigation has shown that an equally important consideration is the time required by the electrons in travelling from the filament to plate with the rapid reversals of polarity encountered in high frequency service. The time of flight of the electrons from the filament to plate becomes an appreciable part of the radio frequency cycle at the shorter wavelengths and if the electrical spacing is large the plate voltage changes lag the grid voltage changes by an appreciable amount. This tube uses, therefore, rather close spacing between the electrodes in order to keep the transit time at a reasonable figure and very short internal connectors to counteract the increased inter-electrode capacity.

The unique structure and arrangement of the base pins is shown in an accompanying sketch. Two of the pins are used for the filament and the remaining two pins are used for the grid and plate connections.

Perhaps the best way to illustrate the comparative output advantages of this tube in 6 meter service and also at the shorter wavelengths is by reference to the

accompanying table. It should be noted that some of these tubes, in particular those which show up the least advantageously in this tabulation are most commonly used at wavelengths well above 6 meters, hence the power output at this wavelength should not be construed as the only measure of their suitability for therapy and other short wave service as contrasted with the

other types of tubes.

Considerable data on high frequency tubes were given in Westinghouse Information Bulletin #4 which was issued in July, 1936. For convenient reference, the accompanying table gives brief ratings of most of the higher frequency tubes, although more complete information will gladly be supplied upon application.

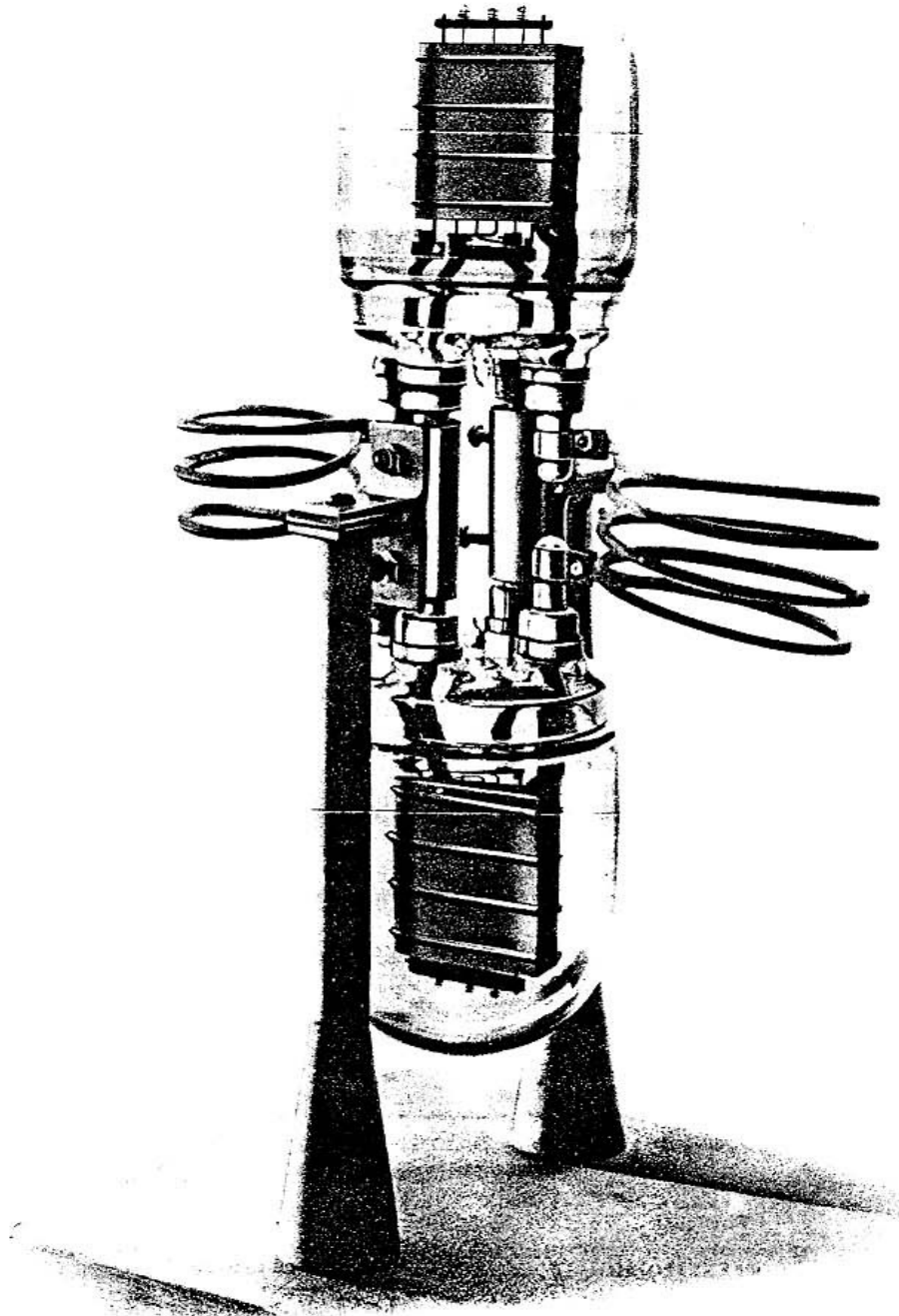

UNIQUE MOUNTING ARRANGEMENT OF  
WL-461 TUBES IN TYPICAL HIGH  
FREQUENCY CIRCUIT

TYPICAL TECHNICAL DATA AND RATING AT 50 MEGACYCLES (6 Meters)

Tube Type	Filament		Plate		Amplification Factor	Typical Useful Or Load Output in Watts With Maximum Input at 6 Meters
	Volts	Amps.	Volts	Amps.		
WL-195	10	3.25	2000	0.14	12	100
WL-196	10	3.25	2000	0.14	35	100
WL-211	10	3.25	700	0.20	12	60
WL-460	10	3.85	2000	0.20	18	300
WL-461	5	11.5	2000	0.25	28	400
WL-463	11	5.0	2000	0.275	22	425
WL-464	10	3.85	2000	0.20	60	300
WL-899	14.5	153.	7500	2.00	30	5000

Typical Six Meter Oscillator Circuit in which All High Frequency Tubes are Tested Before Shipment.

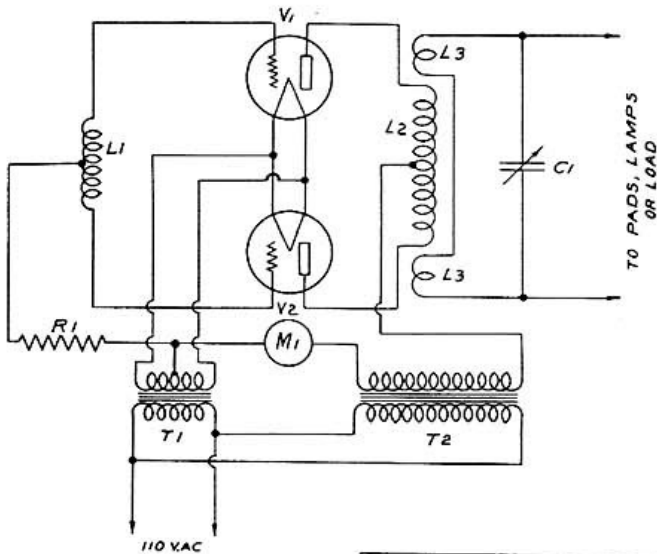

- L1 — 3 Turns 1/8" Copper Tubing 1 1/2" Dia. 2 1/4" Long
- L2 — 5 Turns 1/4" Copper Tubing 3" Dia. 5" Long
- L3 — 2 Turns each end #12 wire, 1" Dia., 1" from L2
- C1 — 5 to 25 M. M. F. Condenser
- R1 — 5000 Ohms 100 Watt
- T1 — 115 to 10 Volt, 10 Amps.
- T2 — 115 to 2500 Volt 0.5 Amp.
- V1 V2 — Tubes under test
- M1 — 0-500 Milliampere D. C.

Last month you were given an opportunity to fill out a card indicating your interest in our electronic bulletins and manifesting a desire to continue receiving them.

If you have not as yet sent in your card will you please send to us promptly the necessary information with your correct address, so as to assure the continuance of your name on our mailing list.

A letter or postcard request will suffice.

For prices and further information write to  
**WESTINGHOUSE**  **LAMP DIVISION**  
**WESTINGHOUSE**  
 ELECTRIC & MANUFACTURING COMPANY  
 SPECIAL PRODUCTS SALES DEPARTMENT  
 BLOOMFIELD, NEW JERSEY